

Technical documentation

Analogue input card with 4 analogue inputs

Table of content

1	List of figures	3
2	General.....	4
3	Example for a configuration.....	5
3.1	netDL 1000 with 6 x 4 ... 20mA (int.) and 6 x 0 ... 5V	5
3.1.1	Connection of the first sensor	5
3.1.2	Connection of the second sensor	6
3.2	netDL 1000 with 6 x 4 ... 20mA and 6 x 0 ... 5V	7
3.2.1	Connection of the first sensor	7
3.2.2	Calculation for the 2-point scaling.....	8
3.2.3	Connection of the second sensor	9
3.3	netDL 1000 with 12 x 0 ... 5V.....	10
3.3.1	Connection of the first sensor	10
3.3.2	Connection of the second sensor	11
3.3.3	Calculation formula for scaling $Y=ax+b$	12
3.4	netDL 1000 with 12 x 4 ... 20mA.....	13
3.4.1	Connection of the first sensor	13
3.4.2	Calculation for the 2-point scaling.....	14
3.4.3	Connection of the second sensor	15
3.4.4	Calculation formula for scaling $Y=ax+b$	16
3.5	netDL 1000 with 6 x 0 ... 50mV and 6 x 4 ... 20mA	17
3.5.1	Connection of the first sensor	17
3.5.2	Connection of the second sensor	18
3.5.3	Calculation formula for scaling $Y=ax+b$	19

1 List of figures

Figure 1: connection assignment for a PT 100	4
Figure 2: connection assignment for a potentiometer	4
Figure 3: connection of the first sensor at terminal G (4 ... 20mA int.)	5
Figure 4: configuration of the first sensor at terminal G with the "Data Logger Operating Program"	5
Figure 5: connection of the second sensor at terminal G (0 ... 5V)	6
Figure 6: configuration of the second analogue input at terminal G with the "Data Logger Operating Program"	6
Figure 7: connection of the first sensor at terminal G (4 ... 20mA)	7
Figure 8: configuration of the first sensor at terminal G with the "Data Logger Operating Program"	7
Figure 9: scaling of the first sensor G with the "Data Logger Operating Program"	8
Figure 10: connection of the first sensor at terminal G (0 ... 5V)	9
Figure 11: configuration of the second sensor at terminal G with the "Data Logger Operating Program"	9
Figure 12: connection of the first sensor at terminal G (0 ... 5V)	10
Figure 13: configuration of the first sensor at terminal G with the "Data Logger Operating Program"	10
Figure 14: connection of the second sensor at terminal G (0 ... 5V) with shown circuit (voltage divider circuit)	11
Figure 15: configuration of the second sensor at terminal G with the "Data Logger Operating Program"	11
Figure 16: scaling of second sensor at terminal G for 0 ... 5V	12
Figure 17: connection of the first sensor at terminal G (4 ... 20mA)	13
Figure 18: configuration of the first sensor at terminal G with the "Data Logger Operating Program"	13
Figure 19: scaling of the first sensor G with the "Data Logger Operating Program"	14
Figure 20: connection of the second sensor at terminal G (4 ... 20 mA)	15
Figure 21: configuration of the second sensor at terminal G with the "Data Logger Operating Program"	15
Figure 22: scaling of second sensor at terminal G for 4 ... 20mA	16
Figure 23: connection of the first sensor at terminal G (0 ... 50mV)	17
Figure 24: configuration of the first sensor at terminal G with the "Data Logger Operating Program"	17
Figure 25: connection of the second sensor at terminal G (4 ... 20 mA)	18
Figure 26: configuration of the second sensor at terminal G with the "Data Logger Operating Program"	18
Figure 27: scaling of second sensor at terminal G for 4 ... 20mA	19

2 General

The technical document describes how to use the analogue input cards with 4 analogue inputs per card. The functionality is described by providing application examples.

As example a netDL 1000 is used with 3 analogue input card, the procedure applies of course for all individual input cards used in netDL 1000 or netDL 500, e.g. a netDL 500 with one analogue input card could have up to four analogue inputs.

Measurement mode of the analogue input card per input terminal:

- 4 ... 20mA
- 0 ... 50mV
- 0 ... 1,25V
- 0 ... 5V
- 0 ... 10V
- Potentiometer 5k Ω
- Temperature Pt 100

Important Note:

If a PT 100 or potentiometer input is required the entire terminal is used and not available for any other analogue input. See connection diagram.

This means per card the maximum of PT100 and potentiometer remains at 2 inputs – each per terminal.

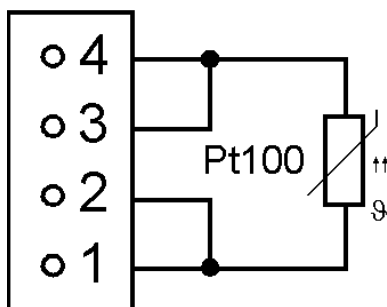

Figure 1: connection assignment for a PT 100

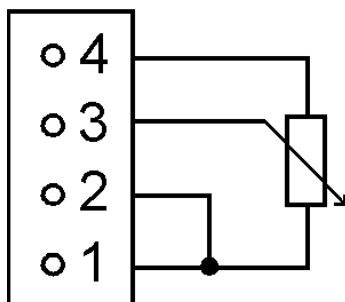

Figure 2: connection assignment for a potentiometer

3 Examples for configurations

3.1 netDL 1000 with 6 x 4 ... 20mA (int.) and 6 x 0 ... 5V

With netDL 1000 a max of 6 x 4 ... 20mA (internal supplied) and 6 x 0 ... 5V inputs can be connected without an external circuit.

3.1.1 Connection of the first sensor

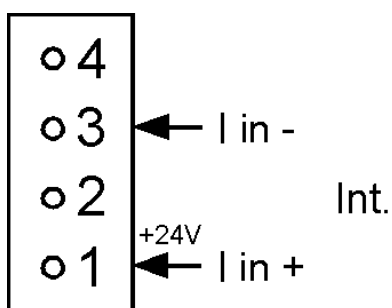

As example it is described how to connect two analogue sensors at terminal G. The same procedure applies for the terminals H, J, K, L and M.

Figure 3: connection of the first sensor at terminal G (4 ... 20mA int.)

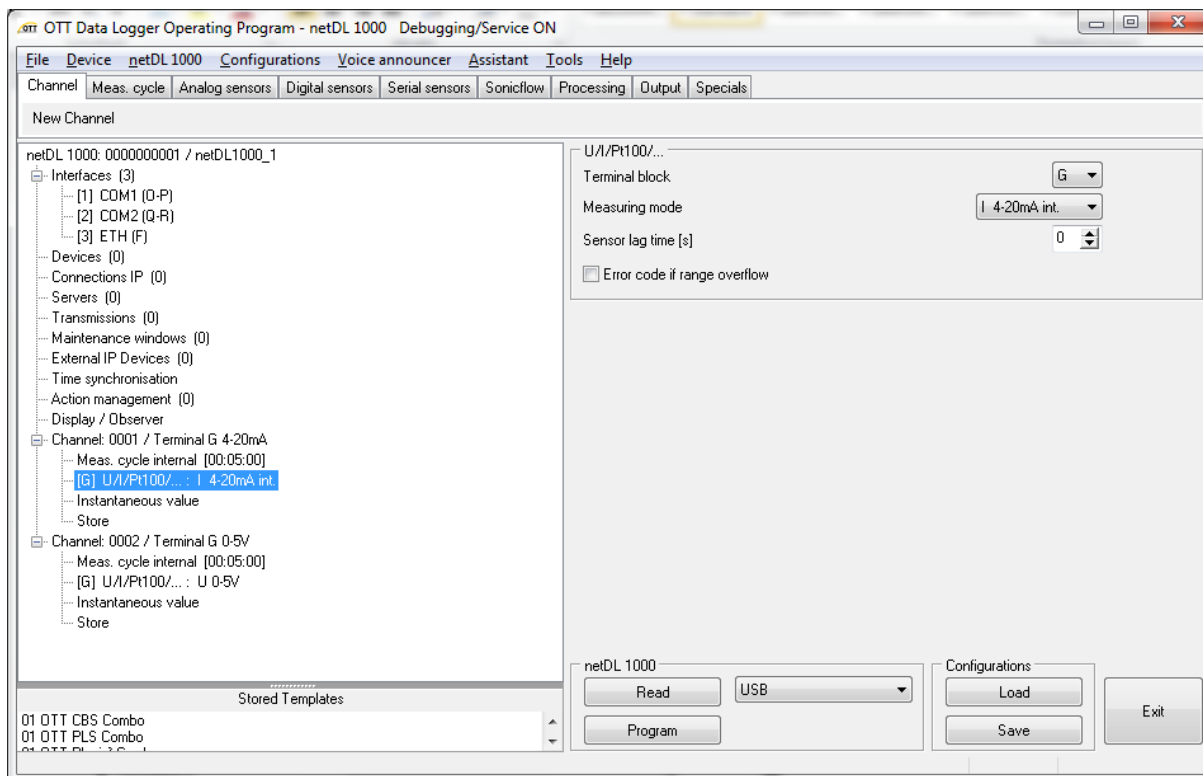

Figure 4: configuration of the first sensor at terminal G with the “Data Logger Operating Program”

3.1.2 Connection of the second sensor

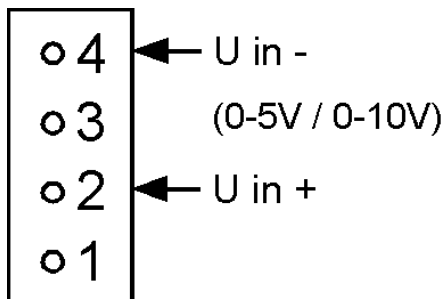

Figure 5: connection of the second sensor at terminal G (0 ... 5V)

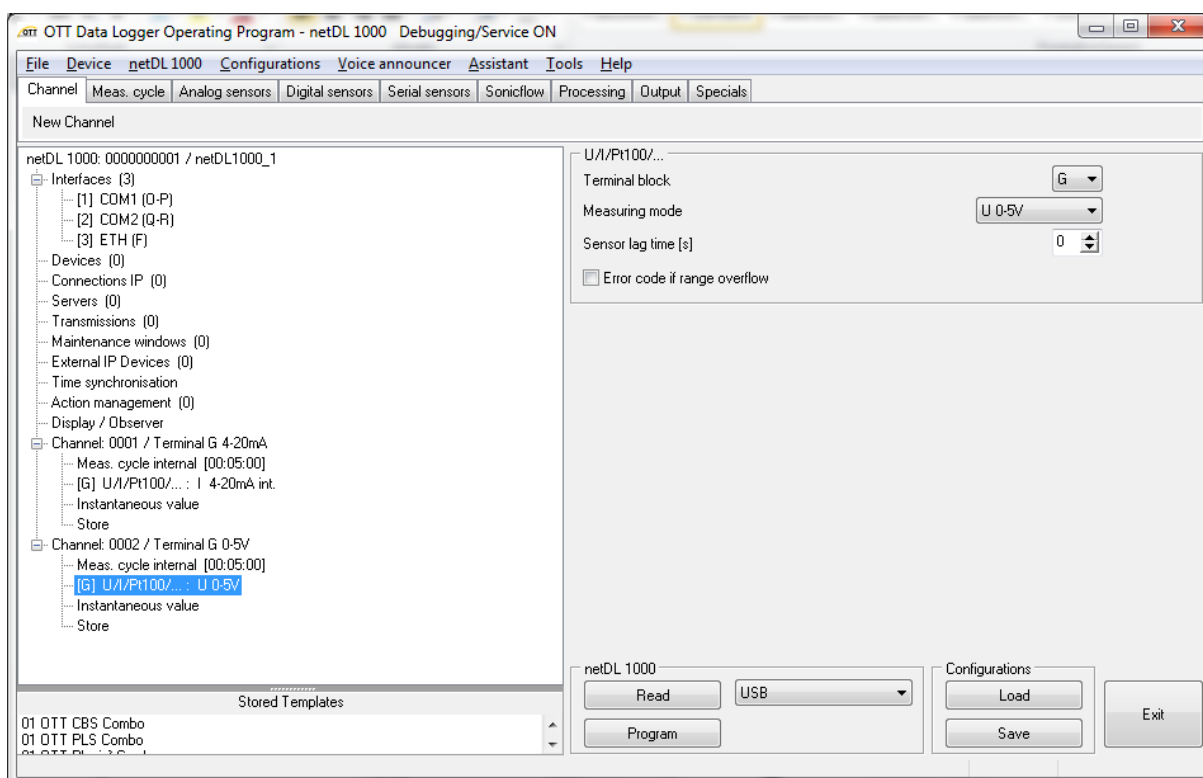

Figure 6: configuration of the second analogue input at terminal G with the “Data Logger Operating Program”

3.2 netDL 1000 with 6 x 4 ... 20mA and 6 x 0 ... 5V

With netDL 1000 a max. of 6 x 4 ... 20mA(external supplied) and 6 x 0 ... 5V inputs can be connected.

3.2.1 Connection of the first sensor

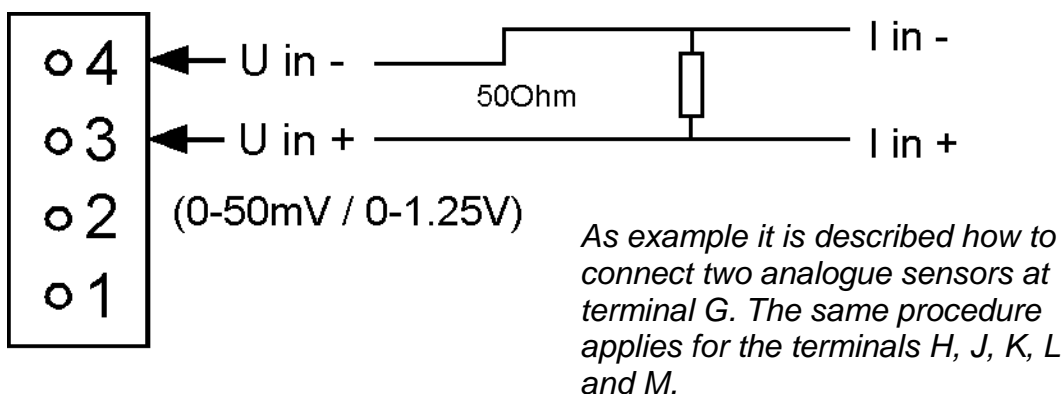

Figure 7: connection of the first sensor at terminal G (4 ... 20mA)

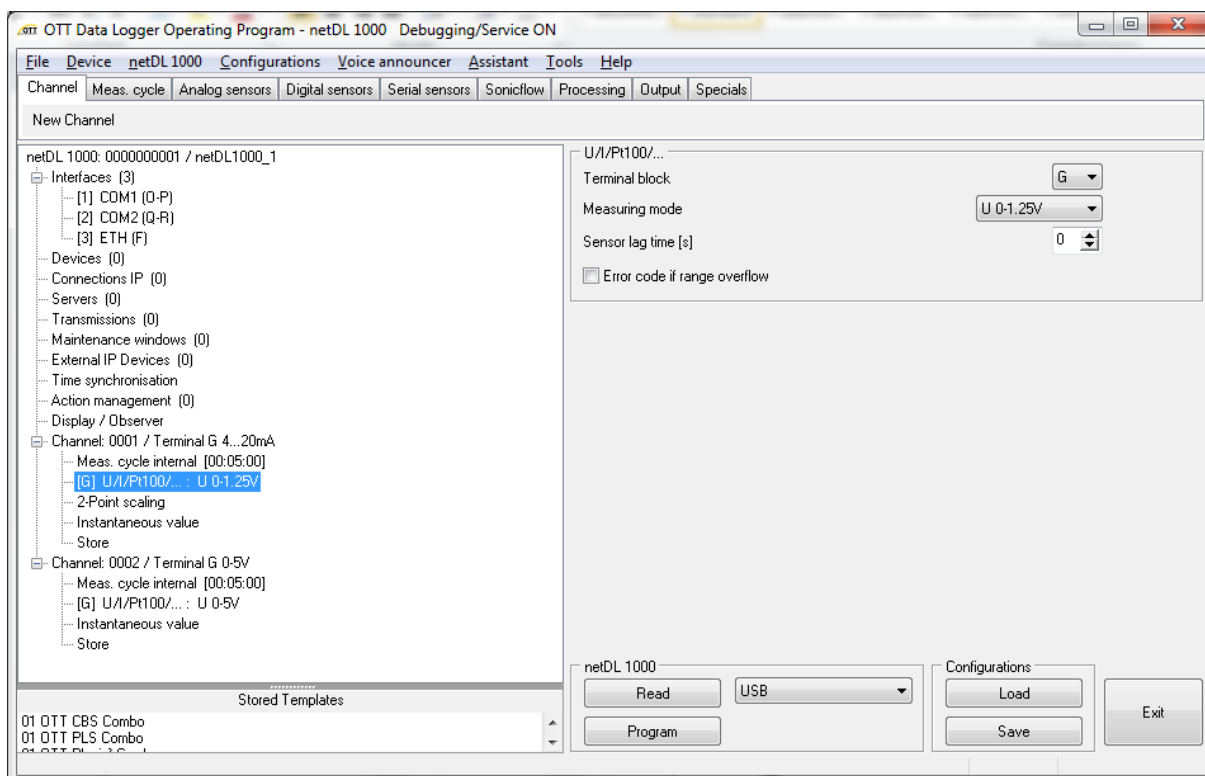

Figure 8: configuration of the first sensor at terminal G with the "Data Logger Operating Program"

3.2.2 Calculation for the 2-point scaling

$$\text{point 1} = 0\text{mA} * 50\Omega = 0\text{V}$$

$$\text{point 2} = 20\text{mA} * 50\Omega = 1\text{V}$$

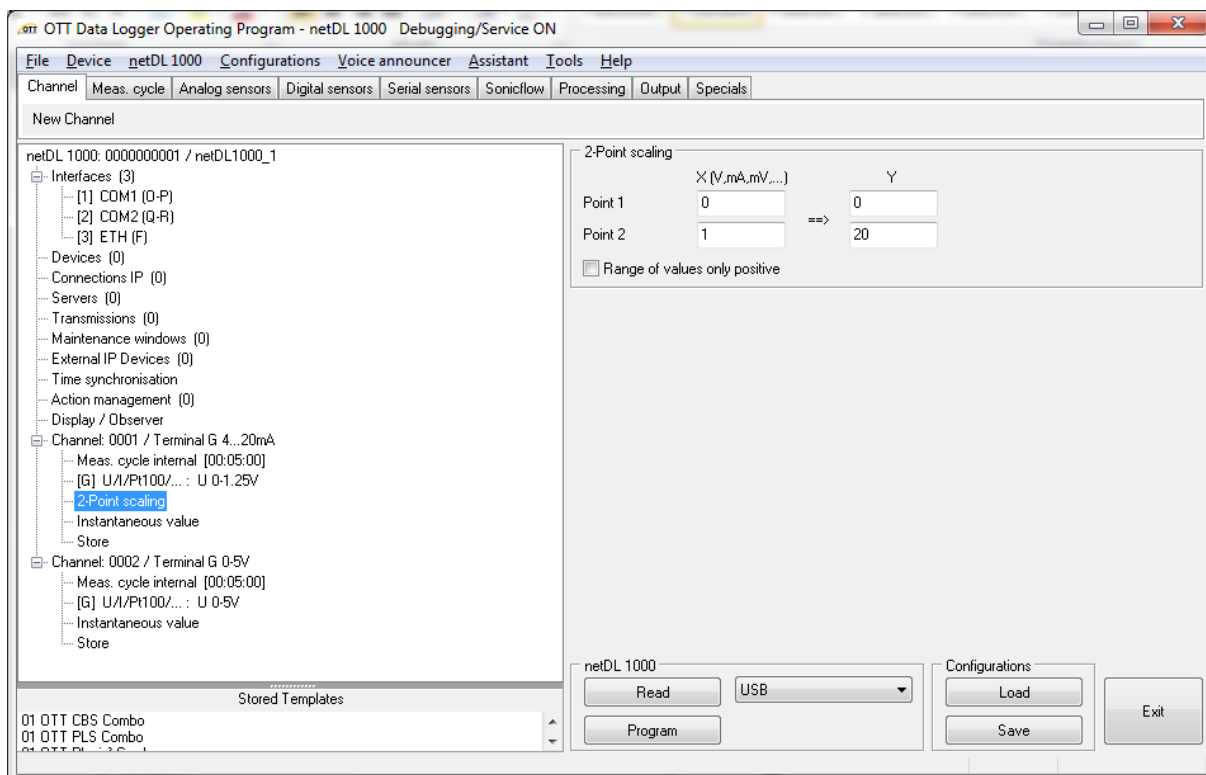

Figure 9: scaling of the first sensor G with the “Data Logger Operating Program”

3.2.3 Connection of the second sensor

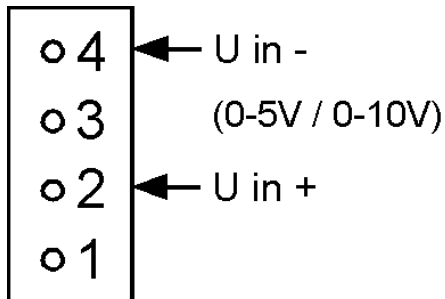

Figure 10: connection of the first sensor at terminal G (0 ... 5V)

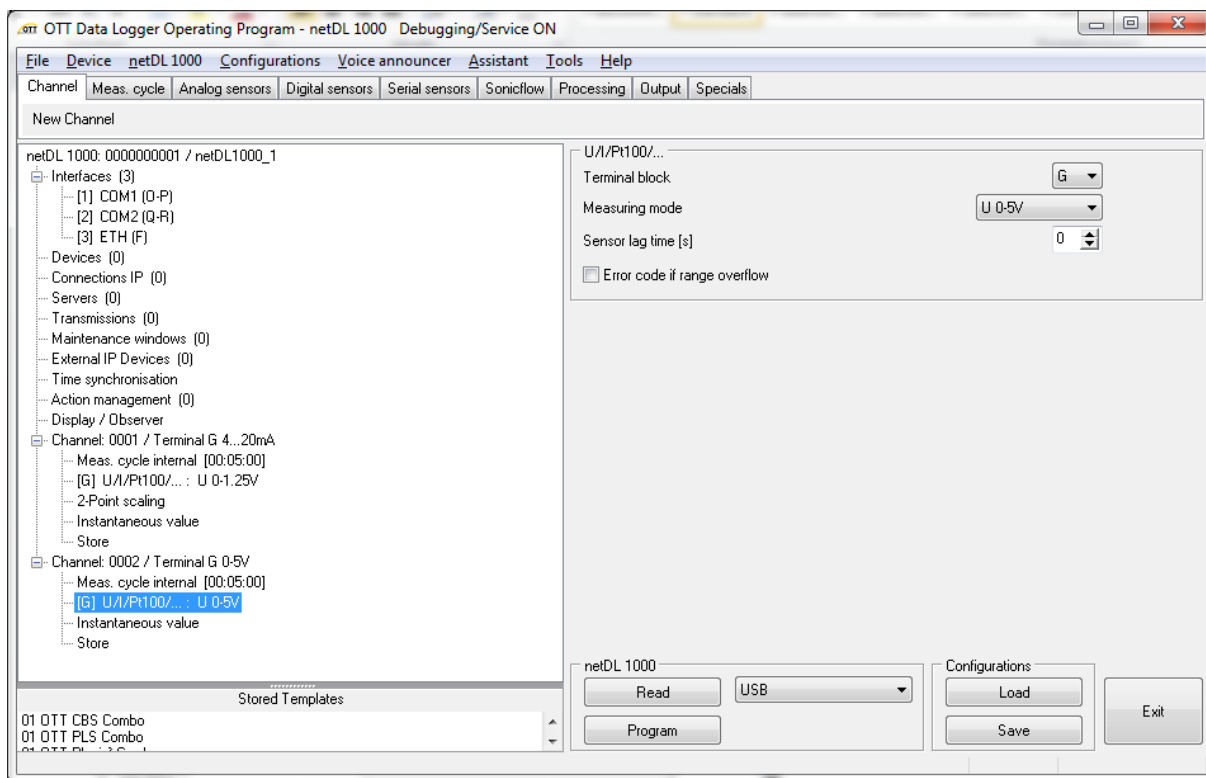
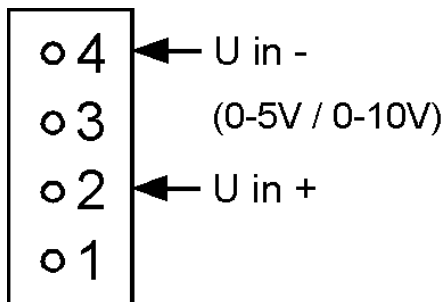

Figure 11: configuration of the second sensor at terminal G with the "Data Logger Operating Program"

3.3 netDL 1000 with 12 x 0 ... 5V

Connection of two sensors at terminal G.

3.3.1 Connection of the first sensor



As example it is described how to connect two analogue sensors at terminal G. The same procedure applies for the terminals H, J, K, L and M.

Figure 12: connection of the first sensor at terminal G (0 ... 5V)

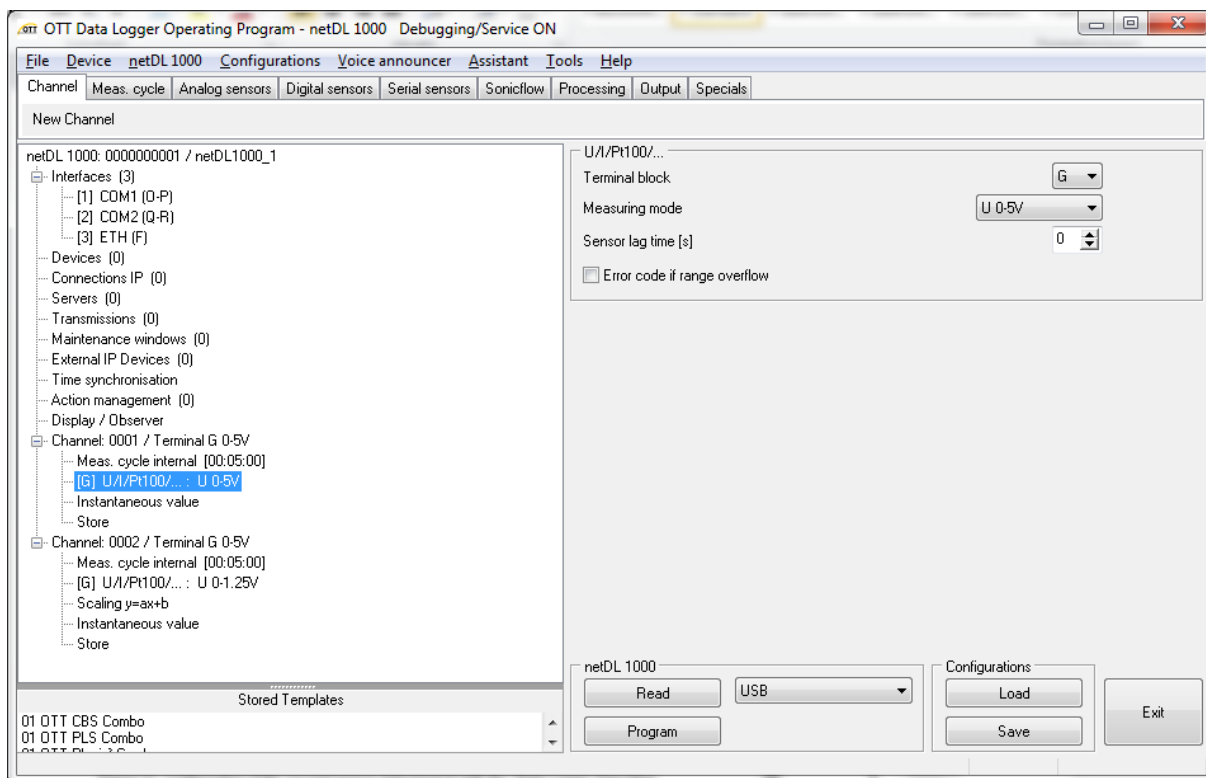

Figure 13: configuration of the first sensor at terminal G with the “Data Logger Operating Program”

3.3.2 Connection of the second sensor

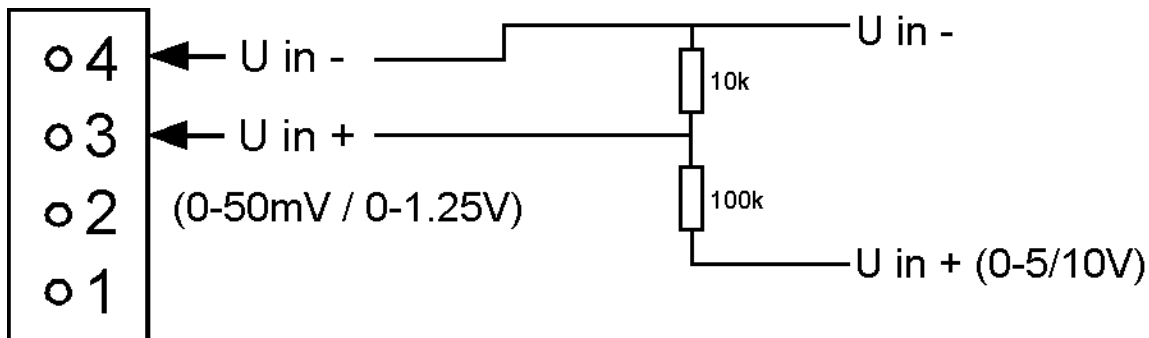

Figure 14: connection of the second sensor at terminal G (0 ... 5V) with shown circuit (voltage divider circuit)

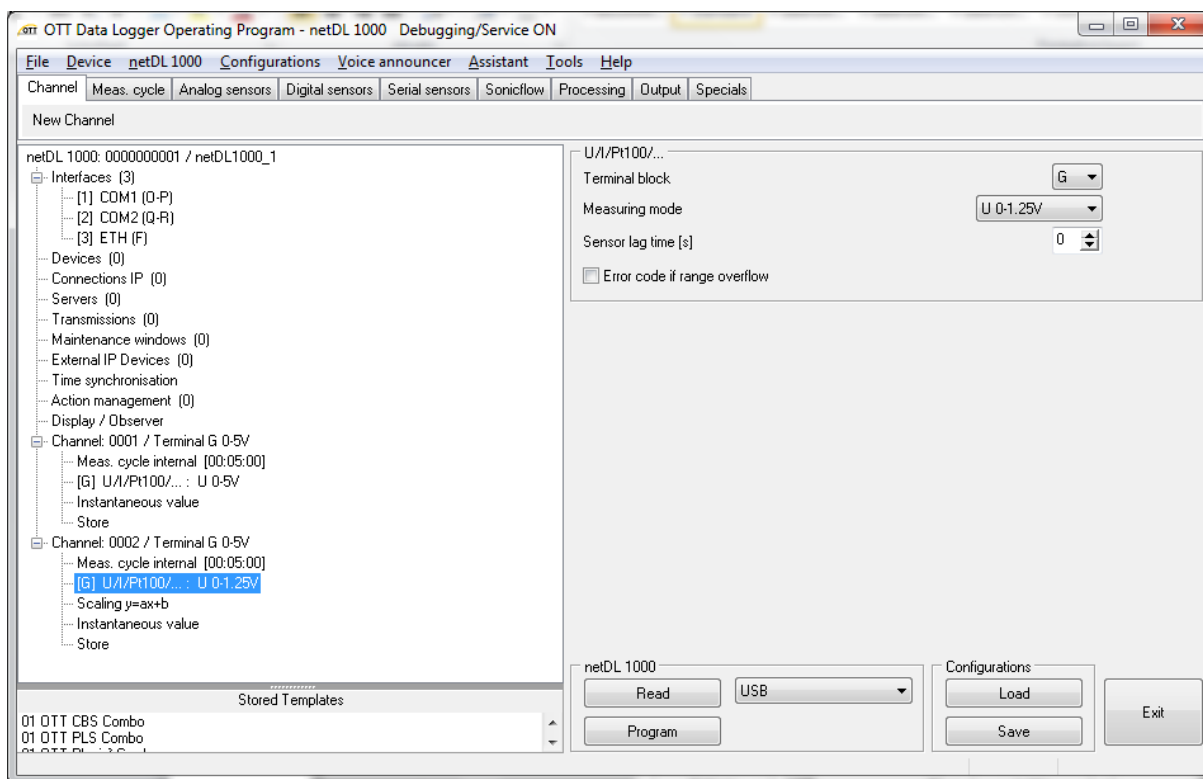

Figure 15: configuration of the second sensor at terminal G with the "Data Logger Operating Program"

3.3.3 Calculation formula for scaling $Y=ax+b$

$$y = \frac{R1 + R2}{R1} * x + a$$

$$y = \frac{100k\Omega + 10k\Omega}{10k\Omega} * x + 0$$

$$y = 11 * x + 0$$

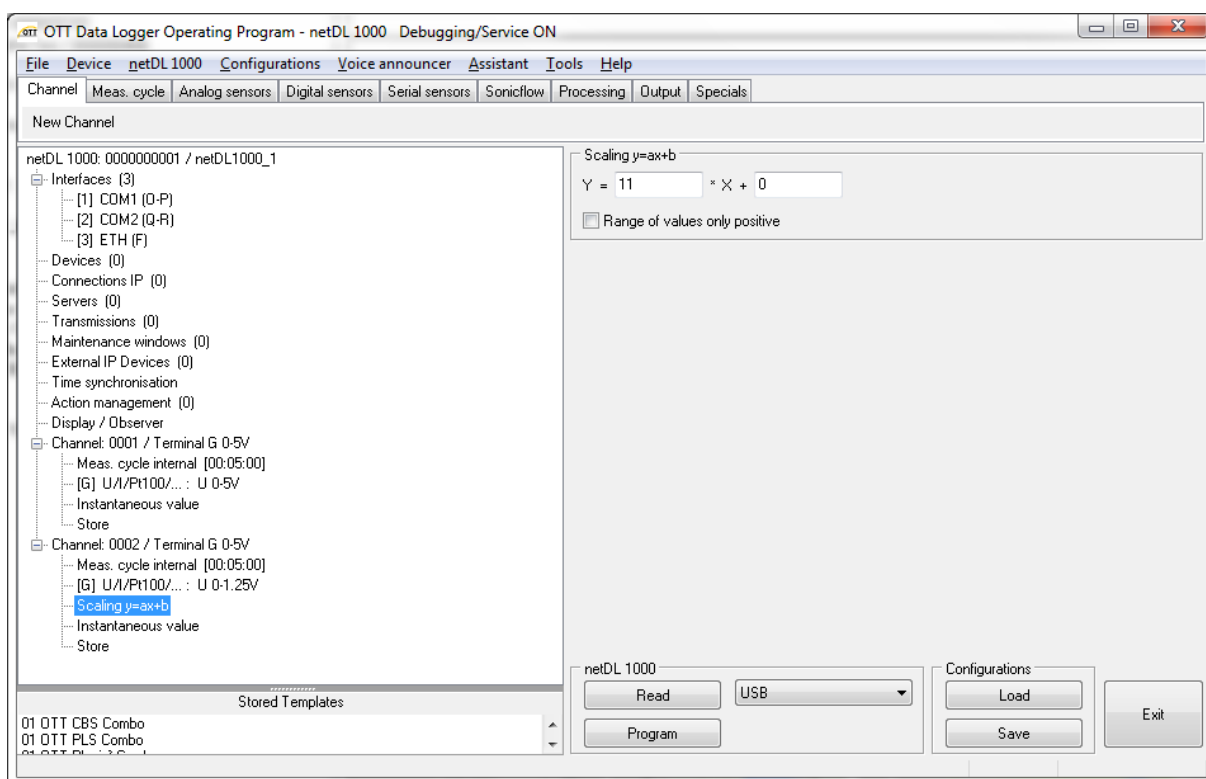

Figure 16: scaling of second sensor at terminal G for 0 ... 5V

3.4 netDL 1000 with 12 x 4 ... 20mA

Connection of two 4 ... 20mA sensors at terminal G. .

3.4.1 Connection of the first sensor

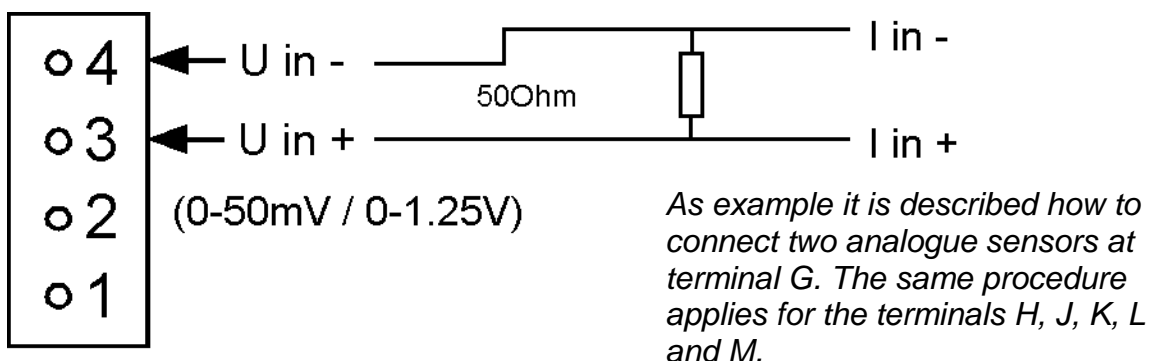

Figure 17: connection of the first sensor at terminal G (4 ... 20mA)

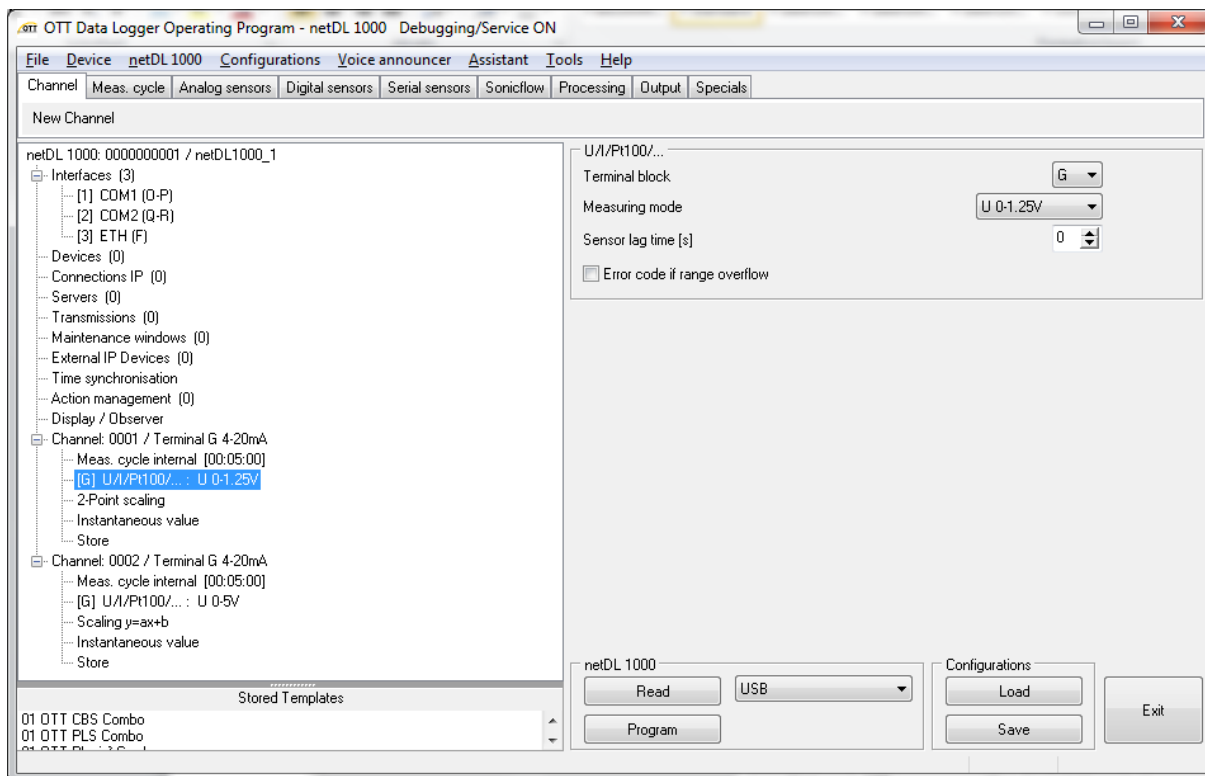

Figure 18: configuration of the first sensor at terminal G with the “Data Logger Operating Program”

3.4.2 Calculation for the 2-point scaling

$$\text{point 1} = 0\text{mA} * 50\Omega = 0\text{V}$$

$$\text{point 2} = 20\text{mA} * 50\Omega = 1\text{V}$$

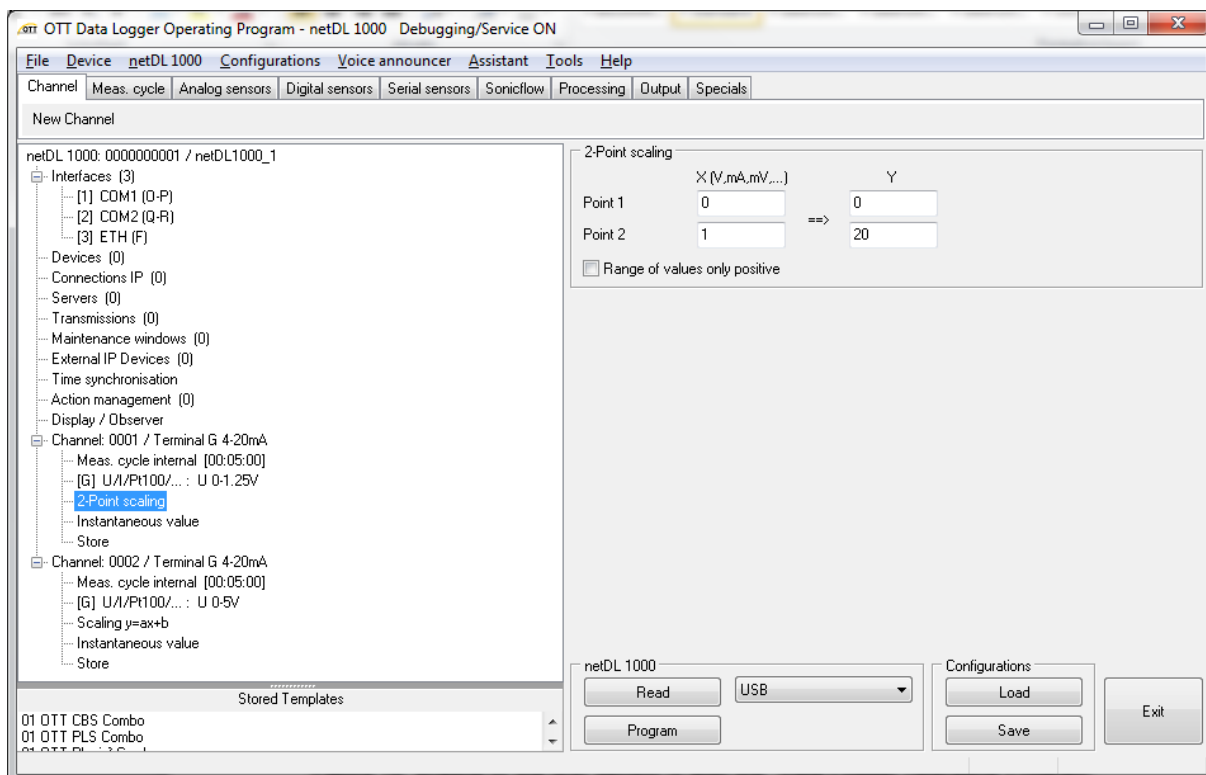

Figure 19: scaling of the first sensor G with the “Data Logger Operating Program”

3.4.3 Connection of the second sensor

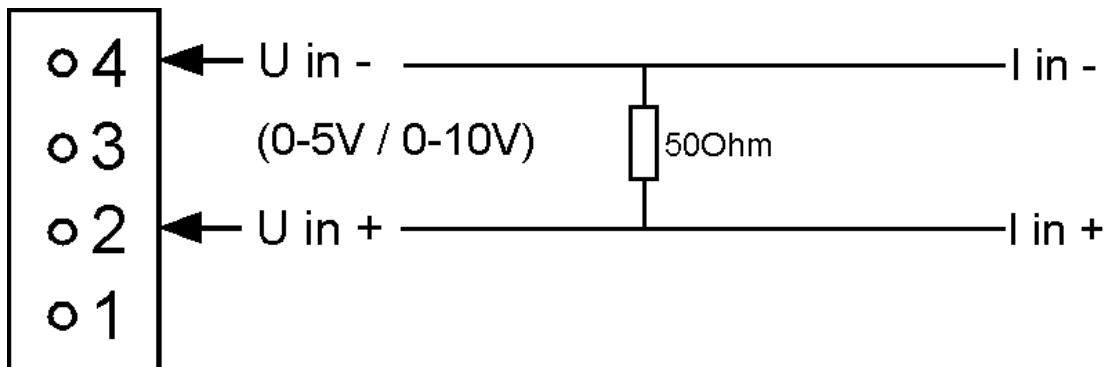

Figure 20: connection of the second sensor at terminal G (4 ... 20 mA)

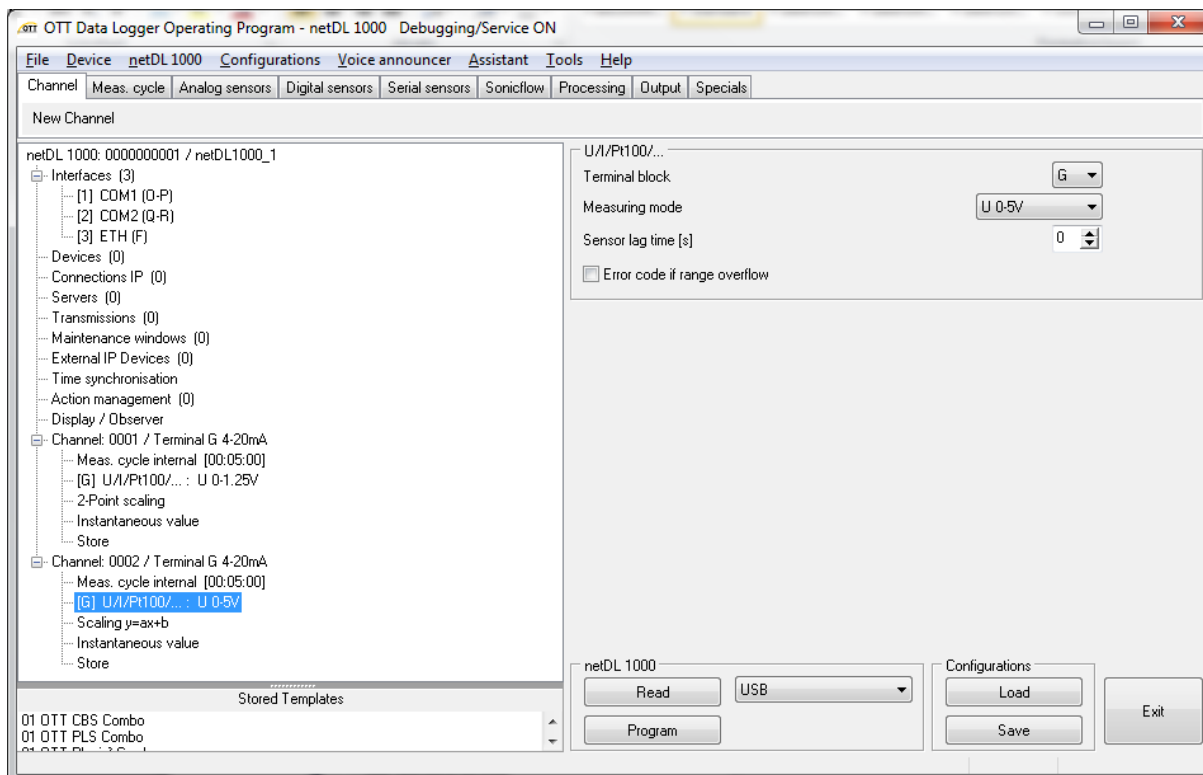

Figure 21: configuration of the second sensor at terminal G with the “Data Logger Operating Program”

3.4.4 Calculation formula for scaling $Y=ax+b$

$$y = \frac{U_{Shunt}}{R_{Shunt}} * x + a$$

$$y = 20 * x + 0 [mA]$$

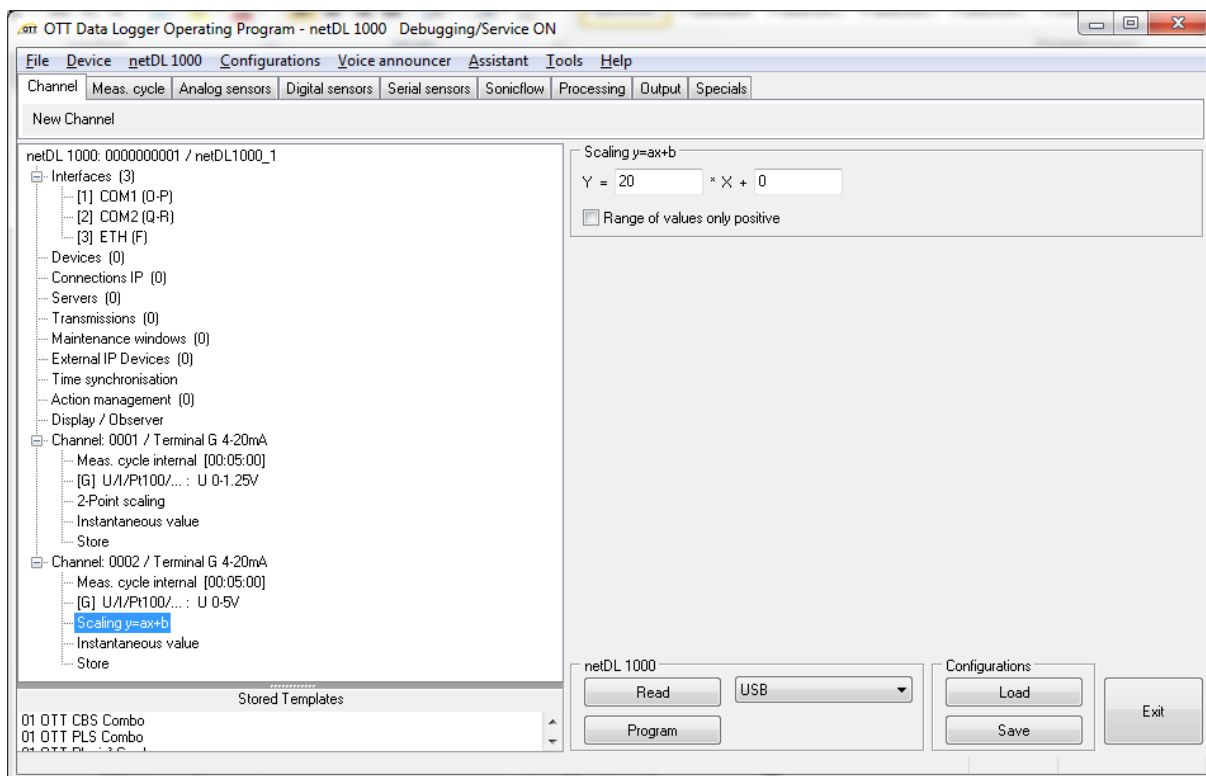
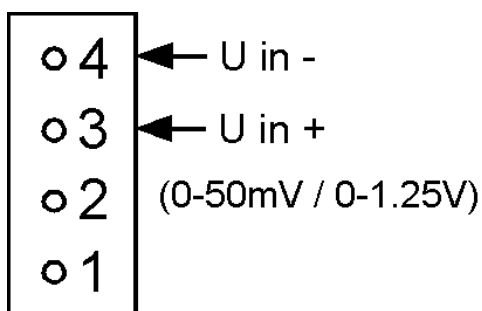

Figure 22: scaling of second sensor at terminal G for 4 ... 20mA

3.5 netDL 1000 with 6 x 0 ... 50mV and 6 x 4 ... 20mA

With netDL 1000 a max. of 6 x 4 ... 20mA and 6 x 0 ... 50mV inputs can be connected.

3.5.1 Connection of the first sensor



Note:
Please use the 0 ...50mV or 0 ... 1,25V input without external circuit; these inputs were internal calibrated to this range.

Figure 23: connection of the first sensor at terminal G (0 ... 50mV)

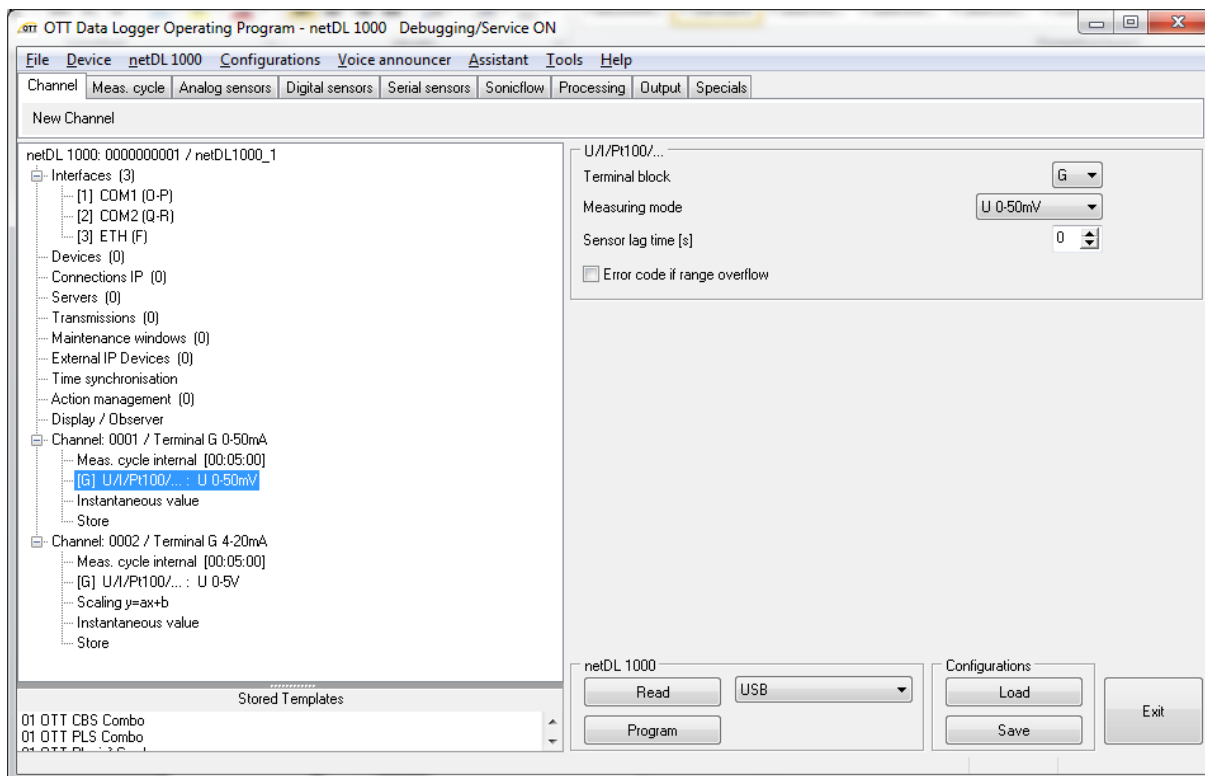

Figure 24: configuration of the first sensor at terminal G with the "Data Logger Operating Program"

3.5.2 Connection of the second sensor

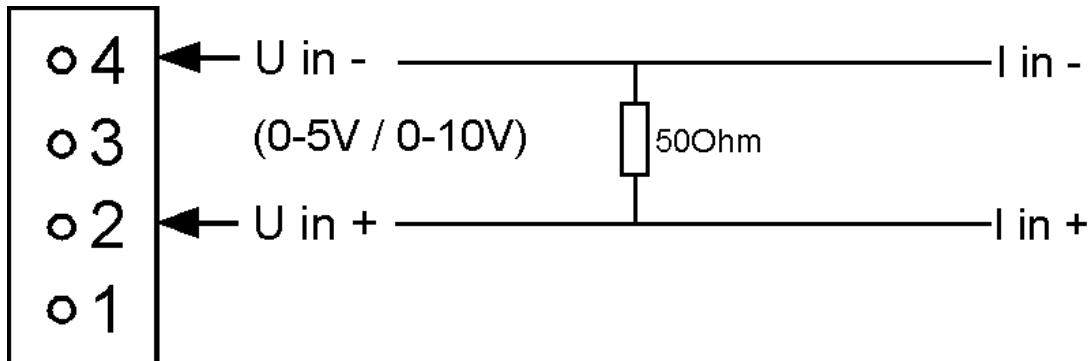

Figure 25: connection of the second sensor at terminal G (4 ... 20 mA)

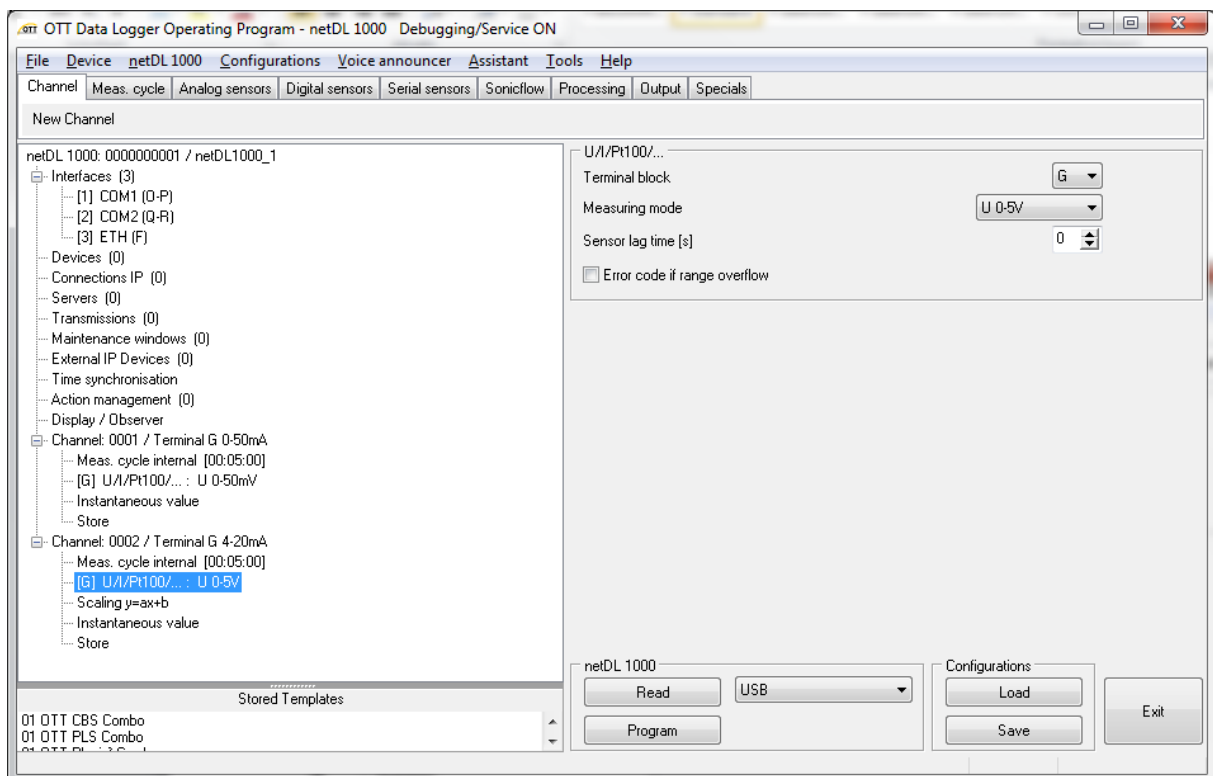

Figure 26: configuration of the second sensor at terminal G with the “Data Logger Operating Program”

3.5.3 Calculation formula for scaling $Y=ax+b$

$$y = \frac{U_{Shunt}}{R_{Shunt}} * x + a$$

$$y = 20 * x + 0 [mA]$$

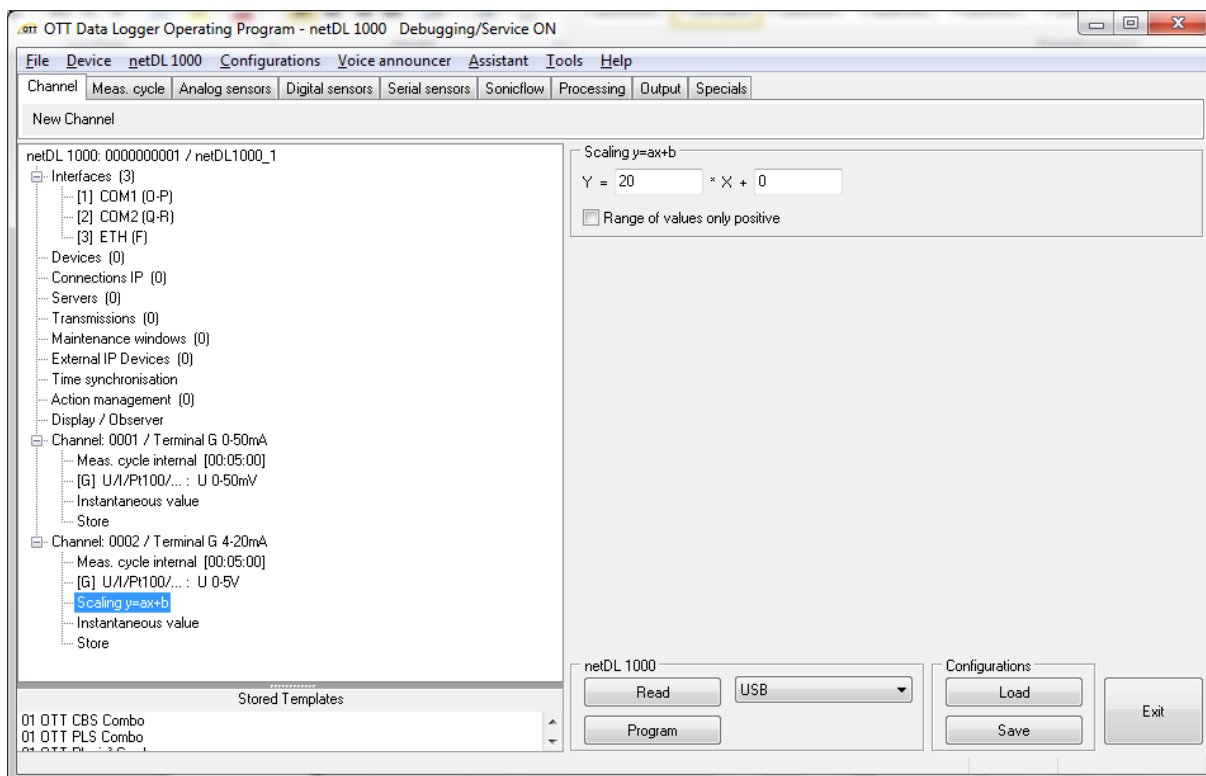

Figure 27: scaling of second sensor at terminal G for 4 ... 20mA