

Quick Reference
Side Looking Doppler
OTT SLD

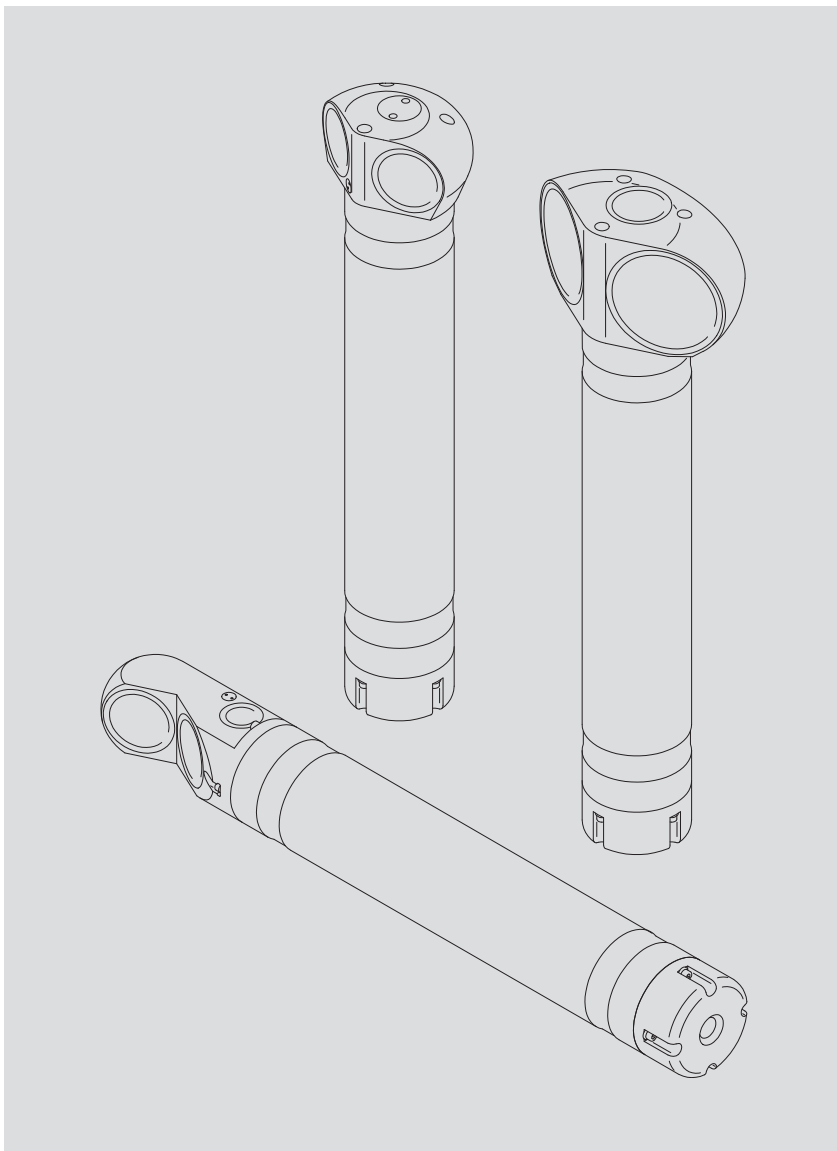

We reserve the right to make technical changes and improvements without notice.

Table of contents

1 System description	5
2 Parts supplied/components of the OTT SLD	6
3 Preparing for installation	7
3.1 Installing the operating software	7
3.2 Cable connection	7
3.3 Checking the communication	8
3.4 Programming the datalogger	8
4 Installation	9
4.1 Calibrating the pressure sensor	9
4.2 Setting the operating parameters	10
4.3 Aligning the sensor	14
4.4 Checking the water level	16
4.5 Checking the range	16
5 Operation	18
5.1 Disconnecting the PC from the sensor	18
5.2 Connection to datalogger	19
5.3 Verifying the data	20
Appendix A	21
A.1 Technical data	21
A.2 Information on electromagnetic compatibility	22
A.3 Firmware update	22
Appendix B – SDI-12 commands and responses	23
B.1 Basic commands	23
B.2 Advanced commands	29
Appendix C – OTT SLD and Modbus fieldbus protocol	30
Appendix D – Representation of the accumulated discharge volumes	33
Appendix E – Installation examples	35
E.1 Example #1 – Installation at a staircase for water level measurement (mounting rail with slide)	36
E.2 Example #2 – Installation at a staircase for water level measurement (dual T rail with roller slide)	37
E.3 Example #3 – Installation at a natural river bank slope (mounting rail with slide)	38
E.4 Example #4 – Installation at a vertical edge wall (mounting rail with slide)	39
E.5 Example #5 – Installation on a concrete base in the river bed	40
E.6 Example #6 – Installation at a sheet pile	41
E.7 Example #7 – Installation at a vertical edge wall (mounting plate)	42

1 System description

During installation, the sensor is connected to the PC and parameterized using a serial interface (a). After completing the installation, serial communication is terminated. Thereafter, the sensor is controlled from the datalogger through SDI-12 or RS-422/RS-485 (b) (SDI-12 protocol).

a) Sensor – Cable – PC/power supply

Fig. 1: Schematic diagram of the wiring configuration used for setting the operating parameters.

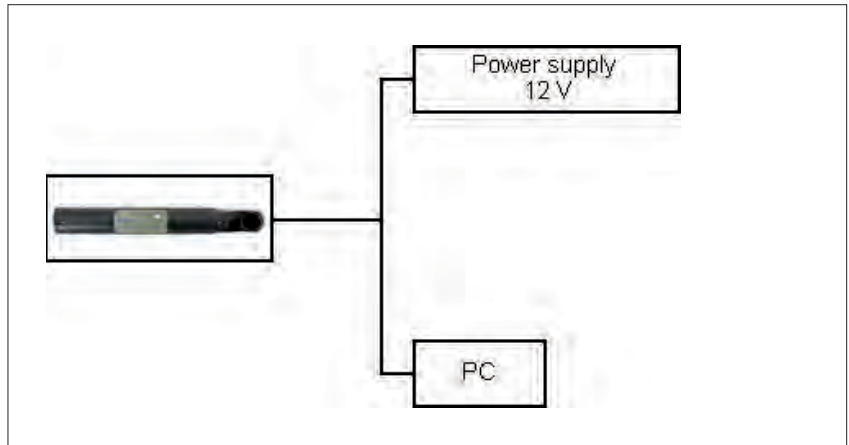

b) Sensor – Cable – Datalogger/power supply

Fig. 2: Schematic diagram of the wiring configuration used for measuring.

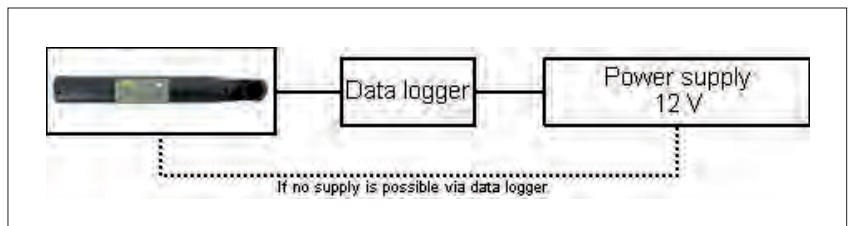

2 Parts supplied/components of the OTT SLD

Please check the contents of the shipping crate against the packing list supplied. The sensor specification may be obtained from the name plate.

Basically, the OTT SLD scope of supply includes 3 items:

- ▶ Connection cable
- ▶ Sensor
- ▶ Operating software CD

Fig. 3: Components of the OTT SLD.

- 1 – Sensor head
- 2 – Sensor housing
- 3 – End piece with connector socket

The figure shows the "Discharge" instrument version (measured variable: flow velocity and discharge); Frequency: 1.0 MHz; horizontal installation; RS-422/RS-485 interface (SDI-12 protocol).



The following instrument versions are available:

- ▶ Discharge
 - Measured variables: Flow velocity and water level;
 - Built-in discharge calculation;
 - Frequencies: 600 kHz, 1.0 MHz, or 2.0 MHz;
 - Design: Horizontal or vertical type;
 - Interfaces: RS-232 and SDI-12 or RS-422/RS-485 (SDI-12 protocol).
- ▶ Velocity (flow velocity)
 - Measured variable: Flow velocity;
 - Frequencies: 600 kHz, 1.0 MHz, or 2.0 MHz;
 - Design: Horizontal or vertical type;
 - Interface: RS-232 and SDI-12 or RS-422/RS-485 (SDI-12 protocol).

3 Preparing for installation

This chapter covers preparing the installation and may be carried out in office. Within the operating software menus, please use dots instead of commas as decimal separators (e.g. 1.5 m for one and a half meters).

3.1 Installing the operating software

The software is run on the Microsoft Windows XP® operating system or later. Insert the CD-ROM into the CD drive. Start the "setup.exe" file. Follow the instructions displayed.

3.2 Cable connection

There are 2 cable options.

- RS-232 in combination with SDI-12 (maximum 65 m);
- RS-422/RS-485 (SDI-12 protocol) (maximum 500 m).

Fig. 4: RS-232 connection diagram.

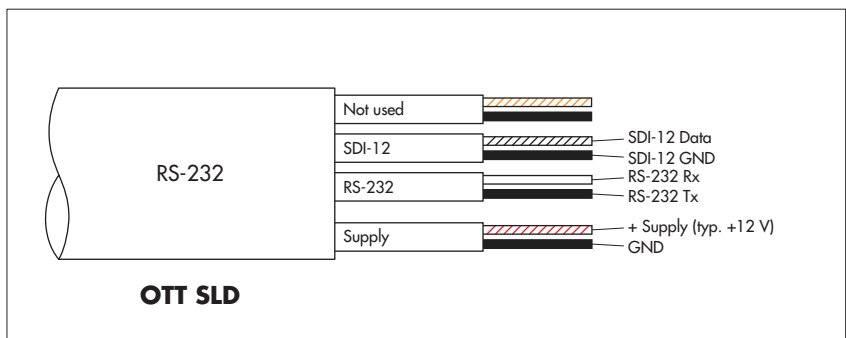
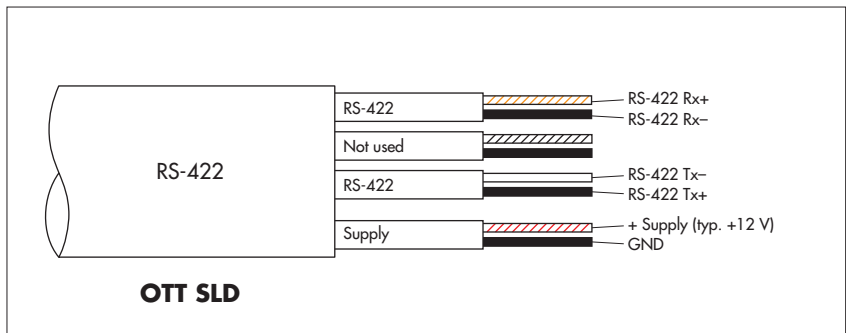

Fig. 5: RS-422 connection diagram.



The cables have a coded underwater connector.

- Spray the contact pins of the connector and the socket with a silicone spray. Use the "Scotch™ 1609" silicone spray manufactured by "3M" for this purpose. Each time you subsequently establish an electrical connection, you must: → Spray again!
- Attach the connector to the plug on the sensor. Secure the connection by tightening the cap nut (manually – don't use a tool).

The second cable end is open. For communication with your PC, you can temporarily attach the sub-D socket (9-pin) provided to this open end.

- Connect this to your PC's serial interface (if necessary use a RS-232/USB adapter).
- Connect "+ Supply" to the positive pole and "GND Supply" to the negative pole of your 12V power supply.

Please note:

- ▶ Never grease the contact pins. Risk of corrosion!
- ▶ Never pull on the cable when disconnecting the connector from the plug!
- ▶ Handle the connector with care! Avoid unnecessary long-term exposure to sunlight!
- ▶ Avoid placing tensile load on the cable!
- ▶ Do not bend the cable!
- ▶ Recommendation: Check the connection on a regular basis.

3.3 Checking the communication

- Start the OTT SLD EasyUse software.
- From the "Communication" menu, select the "Serial Port" option.

Fig. 6: Selecting the serial port.

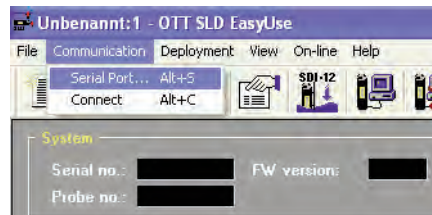

- Select "OK" to confirm the "9600" option of the "Baud rate" item.

Fig. 7: Setting the baud rate.

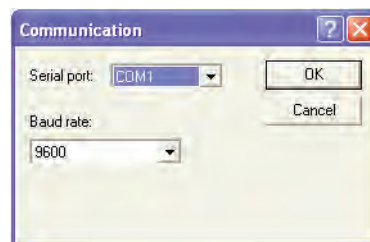

- From "Communication", select the "Connect" option. Now your PC is connected to the sensor.

Fig. 8: Connection test is successful.



3.4 Programming the datalogger

Configure your datalogger (refer to the OTT netDL/OTT DuoSens Operating Instructions). In Appendix B, all SDI-12 commands of the OTT SLD are described. Make sure that the SDI-12 address of the datalogger matches the SDI-12 address of the OTT SLD.

Please note: For an OTT SLD "Discharge" instrument version in combination with an OTT DuoSens, discharge calculation must be performed in the OTT SLD! There is no option for creating a configuration for calculating the discharge within the OTT DuoSens.

4 Installation

Please note: Install the OTT SLD in such a way that it will be immersed in water under any operating conditions. In case this cannot be ensured, provide suitable equipment for automatically disconnecting the operating voltage when the unit is "falling dry". Only thus, safe and trouble-free operation of the OTT SLD will be ensured.

- Route the cable from the place of installation of the sensor to the location of the datalogger. Now repeat all steps described in Chapter 3.

4.1 Calibrating the pressure sensor

The pressure sensor is available only in combination with water level measurement ("Discharge" instrument version).

Calibrate the pressure sensor at the place of installation. The sensor may be calibrated when it is inside or outside the water.

Perform the following steps:

- From the "On-line" menu, select the "Set Pressure Offset" option.

Fig. 9: Set pressure offset.

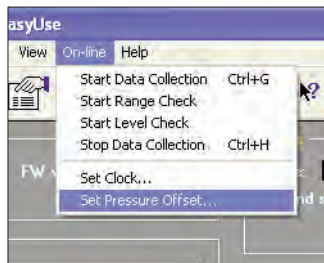

- Set the present water coverage of the sensor (outside the water: 0 m).

Fig. 10: Setting the offset.

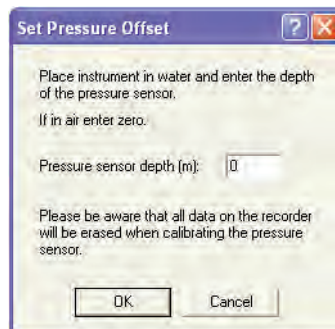

- Select "OK" to confirm. The pressure sensor will be calibrated now.

4.2 Setting the operating parameters

- When you want to create a completely new parameterization,
 - select the "Deployment planning" option from the "Deployment" menu;
 - select "Load From Instrument", when you want to use the configuration stored in the sensor.

Fig. 11: "Deployment" menu.

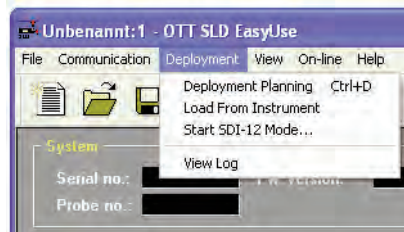
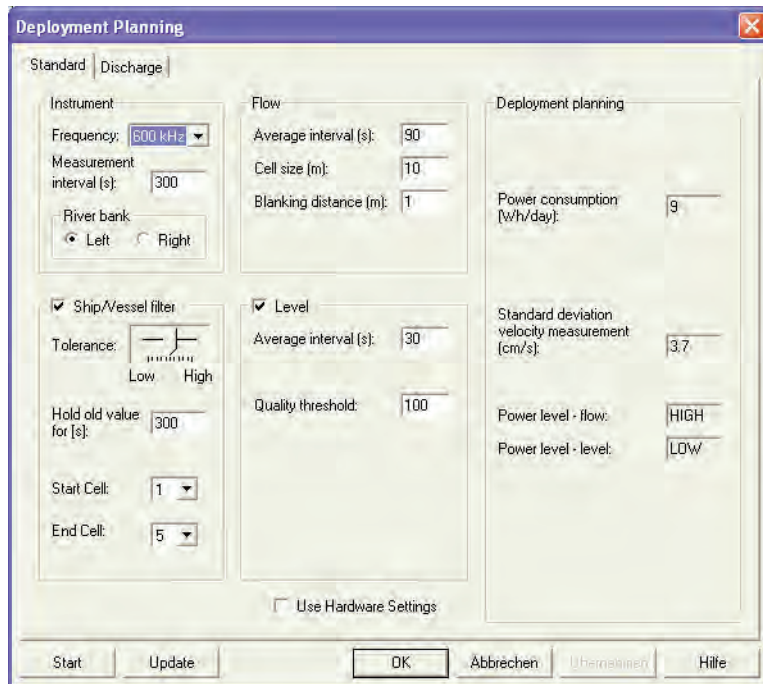

Fig. 12: "Deployment Planning" option, "Standard" tab.



- Select the "Standard" tab and parameterize the following boxes:

Sensor :

- ▶ Frequency
- ▶ Measurement interval

Select the acoustic frequency of the sensor.

Enter the measurement interval. The measurement interval is triggered by the sensor during serial communication only. When a datalogger is connected (SDI-12 protocol), this interval is controlled by it. In such a case, leave the measurement interval of 300 seconds unchanged!

Minimum measurement interval [s] = Flow average interval [s] + Level average interval [s] + 5 s

- ▶ River bank

Select the river bank side (in flow direction) at which the OTT SLD is installed: "Left" or "Right". The OTT SLD is designed to be installed at the right-hand bank side of a flowing waterway.

When it is installed on the left-hand bank side, it will provide negative flow velocities because of its design. When "Left" is selected, the OTT SLD will change the sign of the negative flow velocities the absolute amount of which is, however, correct.

Flow:

- ▶ Average interval Enter the averaging interval for velocity measurement. The recommended values are 60 s (30 s (high flow velocities above 1 m/s) ... 120 s (low flow velocities up to approx. 0.3 m/s).
- ▶ Cell size Enter the cell size (refer to Fig. 13).
- ▶ Blanking distance Enter the blanking distance (refer to Fig. 13).

Fig. 13: Schematic diagram for "Cell size" and "Blanking".

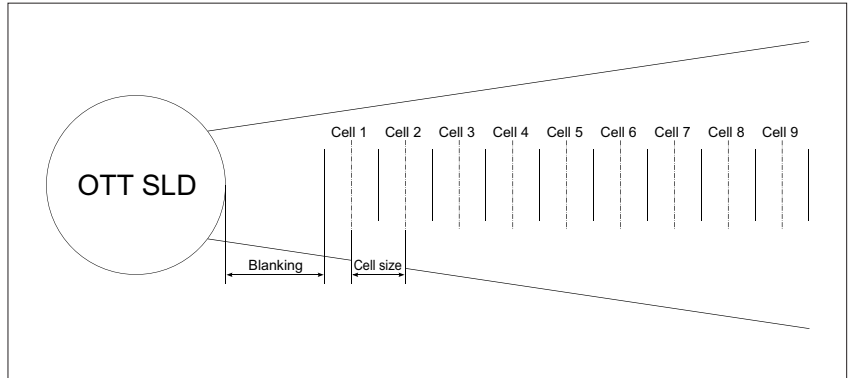

Ship/Vessel filter:

The ship filter is able to detect ships passing the measuring station. To this end, the OTT SLD uses a mathematical algorithm to compare the signal amplitudes of the echoed signals in measuring cells that may be selected. When no ship is passing the measuring station, the signal amplitudes are continuously decreasing with increasing distance to the OTT SLD. When a measuring cell has a signal amplitude caused by reflection at an object that is significantly higher than that of the previous signal, this is considered to be an indication of a ship passing by. In such a case, the OTT SLD will retain the previous measured value for an adjustable period of time.

Please note: The ship filter is available only for the „Discharge“ instrument version and with the „Discharge“ checkbox selected (see Fig. 15)! In any other case the boxes for setting parameters are dimmed.

- ▶ Tolerance Responsiveness of the ship filter.
Recommendation for setting the value: During commissioning, set the slider to the center position between "Low" and "High". Thereafter, use the on-line measurement window to check whether the ship filter is responding appropriately. As necessary, move the slider in the "Low" direction (ship filter has detected a ship passing by although there is only flotsam), or move the slider in the "High" direction (ship filter has not detected that a ship is passing by).
- ▶ Hold old value for [s] Time in seconds the OTT SLD will retain the previous value after the ship filter has detected a ship passing by. Message shown in the online measurement window: "Ship filter holding".
- ▶ Start Cell First measuring cell in which the ship filter is active;
- ▶ End Cell Last measuring cell in which the ship filter is active.

From the defined measured volume, select the range in which ships may actually pass by.

Fig. 14: Available status messages of the ship filter (On-line measurement window).



Level:

- ▶ Average interval Enter the averaging interval for the water level measurement. The recommended value is 15 s (up to 30 s).
- ▶ Quality threshold Enter a value for the quality lower limit of the water level measurement. The optimum setting is between 80 and 120 (also refer to Chapter 4.4).

Caution: For sensors without water level measurement (instrument version: "Velocity"; refer to Chapter 2), the "Level" checkbox must not be selected.

Deployment planning:

- ▶ Power consumption Reflects the energy consumption in Wh per day.
- ▶ Power level – Flow This parameter is set by the OTT SLD. Default: "HIGH".
- ▶ Power level – Level This parameter is set by the OTT SLD. Default: "LOW".

Fig. 15: "Deployment Planning" option, "Discharge" tab.

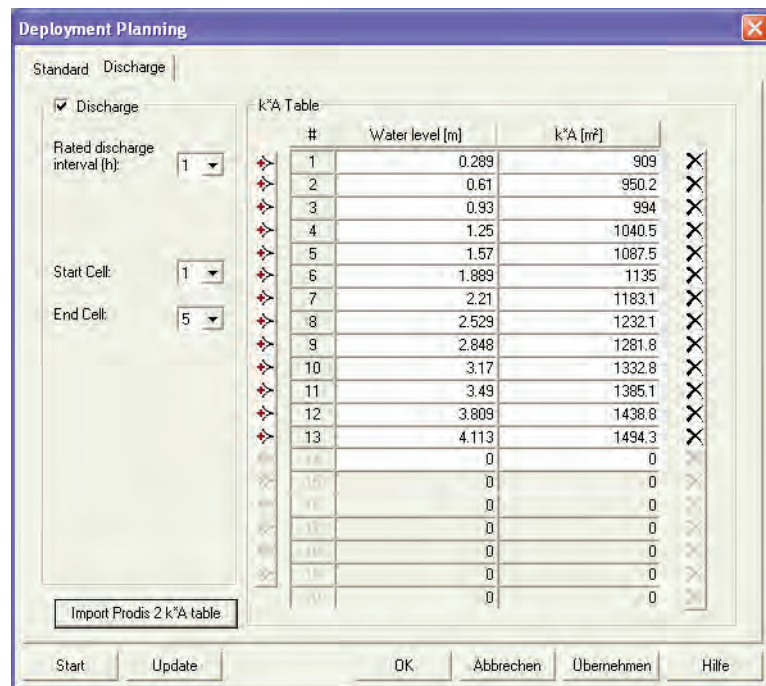

- For "Discharge" instrument version: Select the "Discharge" tab.
- Select the "Discharge" checkbox and parameterize the following boxes:

Discharge:

- ▶ Total volume interval Interval in hours that the OTT SLD uses to determine the accumulated discharge from individual Q values. Value range: 1 ... 24 hours.
- ▶ Start Cell The first measuring cell the OTT SLD uses for discharge calculation. (Example based on the result of the range check of Fig. 22: Cell #1).
- ▶ End Cell The last measuring cell the OTT SLD uses for discharge calculation. (Example based on the result of the range check of Fig. 22: Cell #4).

k*A Table:

- ▶ Water level [m]
- ▶ k*A [m²]

- ▶ Import Prodis 2 k*A table

Data pairs for "Water level" and corrected areas "k*A". You may manually enter individual data pairs or load them into the operating software as a complete table (refer to the "Import Prodis 2 k*A table" button). Loads a complete table into the operating software that was created using the OTT Prodis 2 calibrating software.
File format: "*.XML".

Caution: The k*A table created must match the cells used! When the OTT SLD e.g. uses the cell numbers 3 through 7 for discharge calculation, the k*A table must also have been created based on these cells.

Using the settings made in this window, the OTT SLD calculates the discharge "Q" from the flow velocity measured as well as from the table values for water level and corrected areas (k*A) ("Q" calculation based on the index method). Moreover, the OTT SLD uses the Q values calculated to determine an accumulated discharge value over a selectable period of time. Between two measurement intervals, the discharge is assumed to be constant.

Example

- Measurement interval: 5 minutes (300 seconds)
- Accumulating interval: 1 hour

$$Q_{\text{Accum.}} = Q_1 \times 300 + Q_2 \times 300 + \dots + Q_{11} \times 300 + Q_{12} \times 300$$

Within one accumulating interval, the accumulated discharge Q_{Accum} will increase with every measurement interval. At the beginning of a new accumulating interval, the OTT SLD will reset this value to zero.

- Set the reference height of the OTT SLD water level sensor:
 - When the k*A table used is based on the "coverage" of the water level sensor (OTT SLD ↔ water surface distance) → Enter "0".
 - When the k*A table used is based on another reference point (e.g. "above mean sea level") → Enter the distance from the reference point to the water level sensor.

Fig. 16: Entering the reference height for the OTT SLD water level sensor.

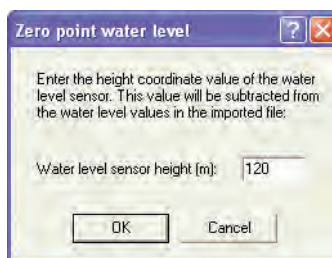

- Select the "OK" button.
- Do not start the online data collection: Select the "No" button.

Fig. 17: Starting the on-line data collection.

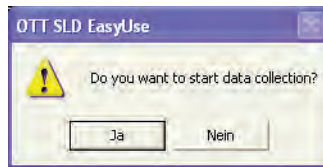

When you want to change the parameterization at a later time, data collection must be stopped! Then proceed as described in this section.

4.3 Aligning the sensor

Attach the sensor to the bracket. Position the sensor in the water as desired. To check proper operation of the sensor, the sensor head must be within the water. The pressure cell requires a minimum water coverage of 15 cm. Ensure that there are no obstructions in the water that may affect sensor operation. Perform the alignment test as follows:

- From the "On-line" menu, select the "Start Level Check" option.

Fig. 18: Starting the level check.

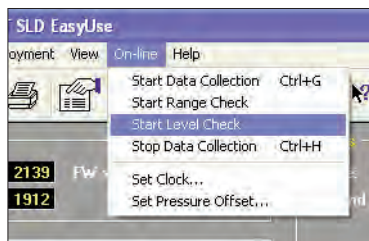

In the lower left corner of the window, "Tilt", "Pitch", and "Roll" are displayed. Move the sensor so that "OK" will be shown for "Tilt". Fix the sensor in this position.

Fig. 19: "Level check" evaluation window.

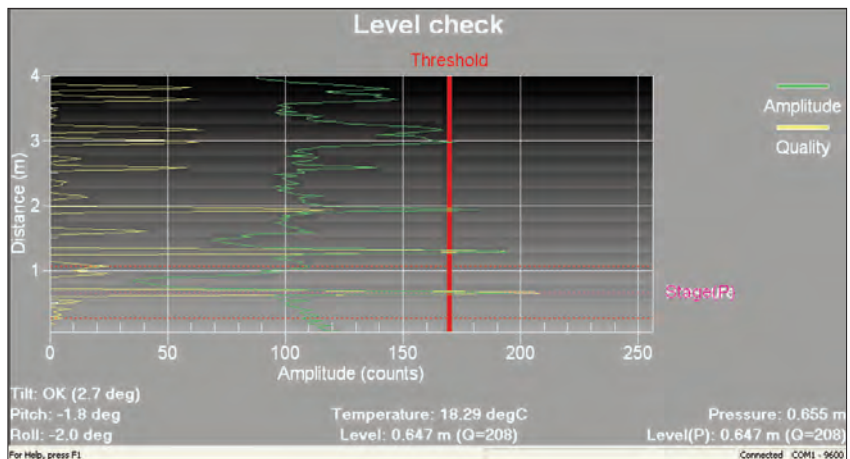

OTT SLD vertical instrument version

OTT SLD horizontal instrument version

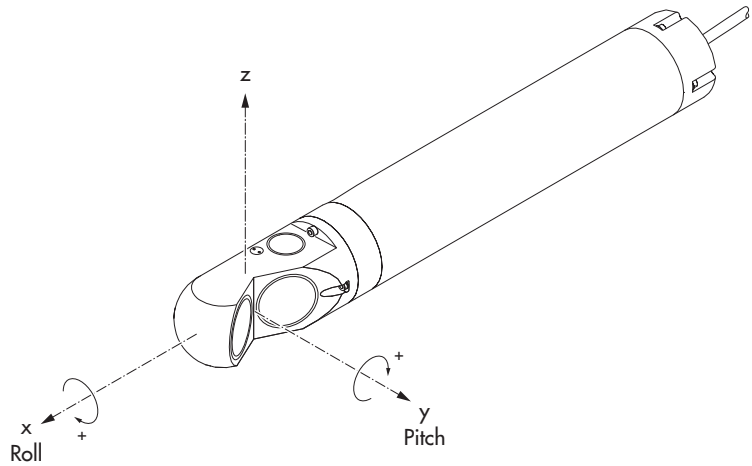
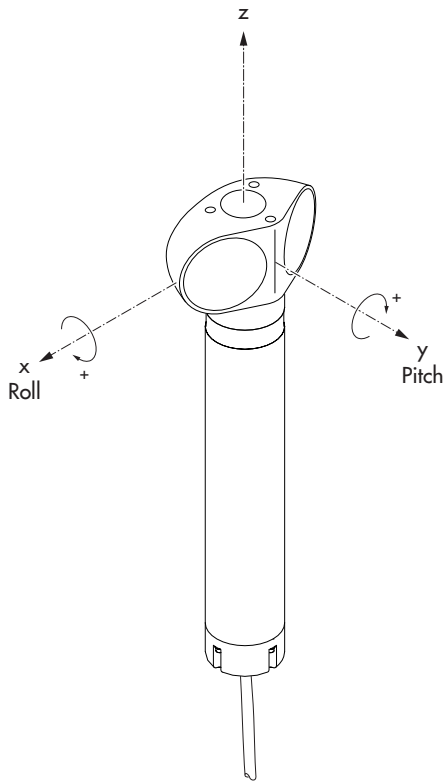

Roll = Roll angle in x axis
Pitch = Tilt angle in y axis

 0° **positive** pitch/roll values* (OTT SLD rotated clockwise)

 0° **negative** pitch/roll values* (OTT SLD rotated counter-clockwise)

When installing the OTT SLD, align it such that the "Tilt"*** value is within the range of -3° ... +3° ("Tilt: OK")
($Tilt = \sqrt{Pitch^2 + Roll^2}$)

* Value range: $\pm 25^\circ$ (shown in gray, beyond this value, the OTT SLD will set bit 3/ bit 4 in status value to "1")
** Refer to "Level Check" window ("On-line" menu) in OTT EasyUse software

Fig. 20: Pitch/Roll values when aligning the OTT SLD.

4.4 Checking the water level

The water level is determined by evaluating the runtime an acoustic signal takes from the sensor to the water surface and back. Runtime measurement is supported by a pressure sensor.

Figure 19 shows the strength of the amplitude (green) and the quality (yellow) of the received (reflected) signal in the horizontal axis. The vertical axis shows the distance of the water surface to the sensor. The dashed horizontal white line shows the water surface height determined by the pressure sensor, and the purple line shows the water surface height measured by the acoustic sensor. The sensor takes into account only those values that are within ± 30 cm of the pressure sensor value (red dashed lines).

Furthermore, the screen shows information on the alignment of the sensor at the bottom left-hand side (refer to Chapter 4.3), the water temperature in °C (degC) and water depth (Level) in the bottom center, and the value of the pressure sensor (Pressure) as well as the combined water level (Level (P)) at the bottom right-hand side. The combined water level includes the pressure and acoustic sensors to avoid incorrect measurements caused by e.g. reflections. For further calculations, the combined water level is recommended to be used.

Figure 19 shows 3 significant amplitudes at approx. 65 cm, 130 cm, and 195 cm. This is an indication of multiple reflections. In the "Deployment" dialog, set the threshold (Threshold – the red vertical line in the Figure) so that the quality and amplitude values corresponding to the present water height will exceed the threshold. Any values below the threshold will not be included in the calculation.

■ Complete the test: From the "On-line" menu, select the "Stop Data Collection" option.

4.5 Checking the range

The range check is to ensure that the flow velocity is gathered in an optimum way. It helps identify underwater obstructions and adapt the size of the measuring cell and the blanking distance to the river geometry. Figures 22 and 23 show the distance from the sensor and the position of the measuring cells in the horizontal axis and the strength of the received (reflected) signal in the vertical axis.

■ From the "On-line" menu, select the "Start Range Check" option.

Fig. 21: Starting the range check.

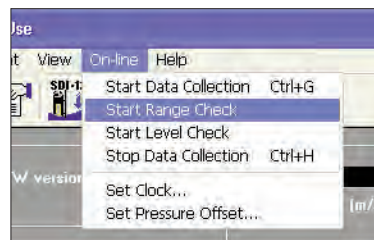

The following figures show typical curves obtained from range checks. To get a better overview, you may remove individual curves by disabling the respective checkboxes ([X] → []). It is recommended to display beams 1 and 2 only (disable beams 3 and 4).

Figure 22 shows a test that provides an optimum result. For both acoustic beams, the strength of the echo signal continuously decreases over the entire distance. The increase obtained in cell #5 is caused by reflections from the opposite bank. Therefore, only cells #1 through #4 should be used. Please make sure that the last cell of the measured value ends at 80% of the waterway width (based on the width in the mounting height of the sensor) to prevent interference from the opposite bank affecting the signal evaluation.

Fig. 22: Successful range check.

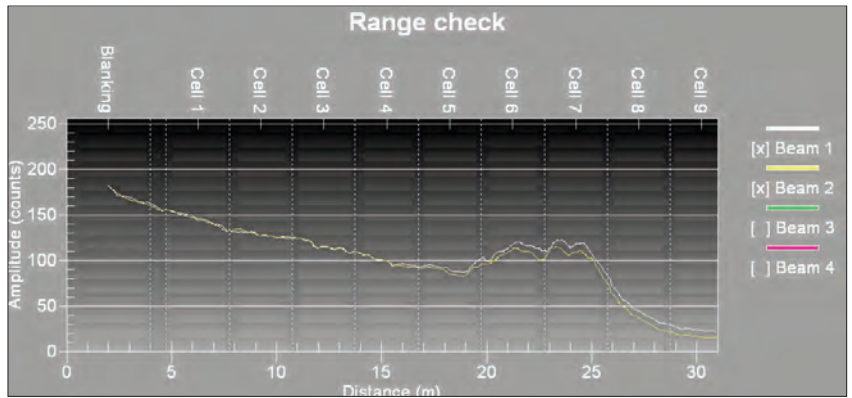

The red area in Figure 23 identifies those cells in which the reflected signal is too weak to be evaluated. That means that even cell #5 does not provide usable data. Furthermore, signal amplifications at 2.5 m and 10 m are indications of interference (e.g. obstructions).

Fig. 23: Range check failed.

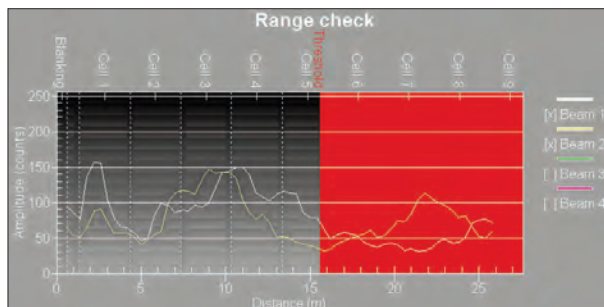

- Complete the test: From the "On-line" menu, select the "Stop Data Collection" option.

5 Operation

After completing all tests to be done during installation, the sensor is ready for use.

5.1 Disconnecting the PC from the sensor

Check whether the datalogger measurement interval is larger than the averaging interval of the flow or level measurements (for the formula, refer to Chapter 4.2).

- From the "Deployment" menu, select the "Start SDI-12 Mode" option.

Fig. 24: Starting SDI-12.

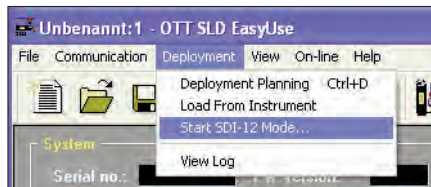

- Set the sensor address. The default address is "0". When the sensor is fitted with an RS-422 interface, select "SDI-12 over RS-485".

Fig. 25: Setting the SDI-12 address.

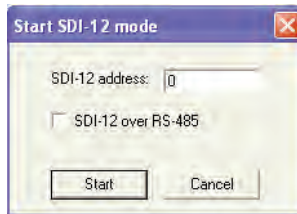

- Select the "Start" button.
- Save the configuration to your PC.

Fig. 26: Saving the deployment.

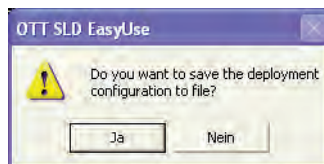

- In the subsequent window, the final parameterization of the sensor is displayed. Please check it carefully. Use the "Confirm" button to confirm the configuration.

Fig. 27: Confirming the deployment.

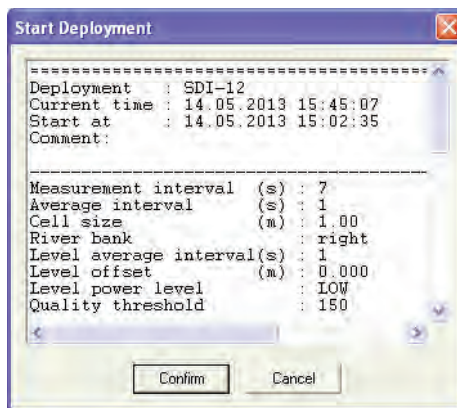

Now you have successfully configured the OTT SLD.

- Use the "OK" button to disconnect the connection to the PC.

Fig. 28: SDI-12 started.

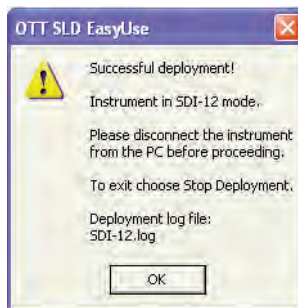

- Also, physically disconnect the connection to the PC.

5.2 Connection to datalogger

- Connect the sensor to the OTT netDL/OTT DuoSens using the SDI-12 interface (refer to the OTT netDL/OTT DuoSens Operating Instructions).

Fig. 29: Connecting the OTT SLD to OTT DuoSens/OTT netDL using the SDI-12 interface.

The GND connection represented by the dashed line is necessary only in case the OTT SLD/OTT netDL, and the OTT DuoSens are powered by separate power supplies.

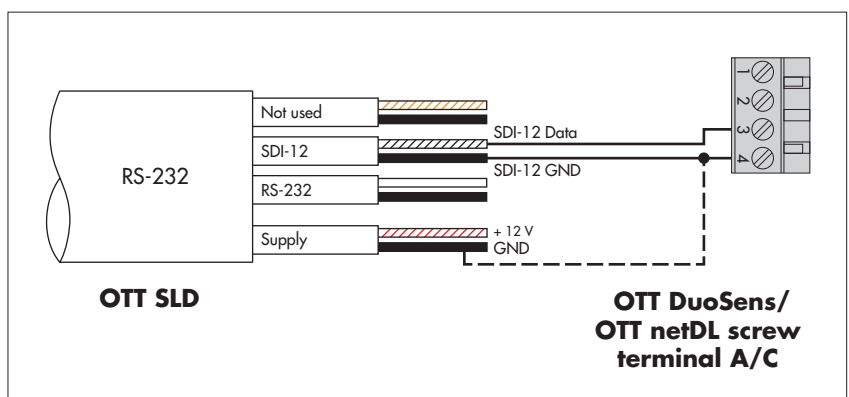

- Alternatively: Connect the sensor to the OTT DuoSens using the RS-485 interface (SDI-12 protocol).

Fig. 30: Connecting the OTT SLD to the OTT DuoSens using the RS-485 interface (SDI-12 via RS-485).

The GND connection represented by the dashed line is necessary only in case the OTT SLD and the OTT DuoSens are powered by separate power supplies.

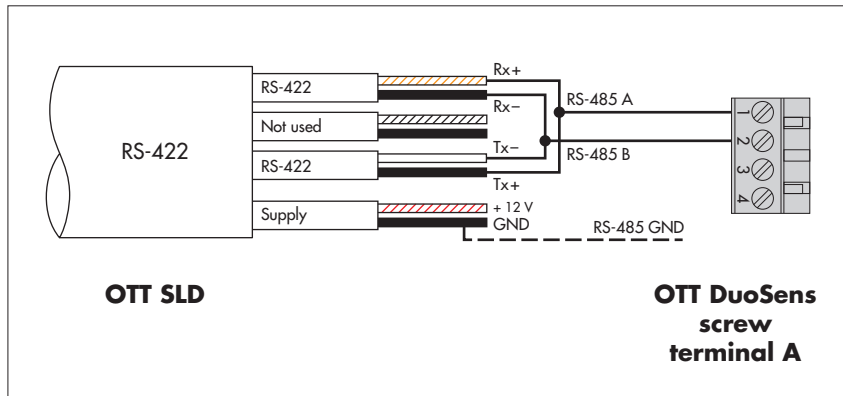

- Alternatively: Connect the sensor to the OTT netDL using the RS-485 interface (SDI-12 protocol).

Fig. 31: Connecting the OTT SLD to the OTT netDL using the RS-485 interface (SDI-12 via RS-485).

The GND connection represented by the dashed line is necessary only in case the OTT SLD and the OTT netDL are powered by separate power supplies.

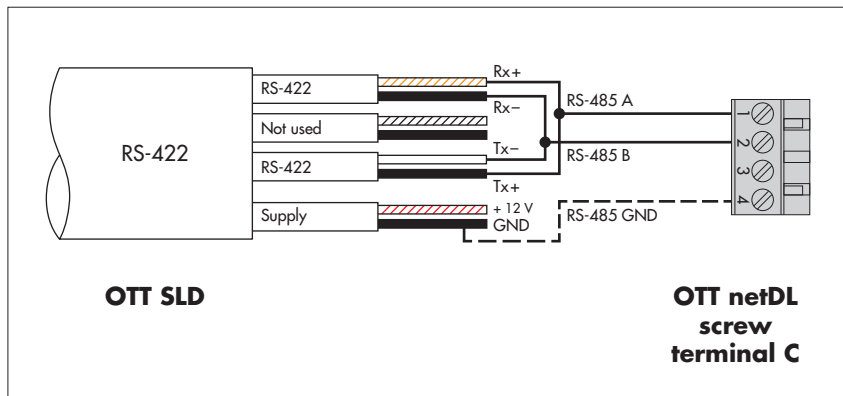

- The cables have a coded underwater connector. Connect this to the sensor. Please observe all of the information from section 3.2 (use a silicon spray)!

5.3 Verifying the data

On the instantaneous value display of the OTT netDL/OTT DuoSens datalogger, the OTT SLD instantaneous values are shown. Please note the time offset caused by the configured intervals.

Appendix A

A.1 Technical Data

Supply voltage	12 ... 16 V DC, typ. 12 V		
Power consumption	50 ... 500 mW (depending on measurement interval)		
Flow velocity measurement			
Measuring range	-10 m/s ... +10 m/s		
Accuracy	1 % of meas. value ± 5 mm/s		
Resolution	1 mm/s		
Measurement averaging time	1 s ... 3600 s		
Number of measuring cells	9		
	OTT SLD 2.0 MHz	OTT SLD 1.0 MHz	OTT SLD 0.6 MHz
Frequency	2 MHz	1 MHz	600 kHz
Blanking	0.1 ... 8 m	0.3 ... 15 m	0.5 ... 30 m
Cell size	0.2 ... 2 m	1 ... 4 m	2 ... 10 m
Range	10 m	25 m	80 m
Water level measurement (optional)			
Measuring range	0.15 ... 10 m		
Accuracy	± 3 mm		
Resolution	1 mm		
Measurement averaging time	1 s ... 3600 s		
Minimum water depth above instrument	0.15 m		
Pressure cell (optional)	piezo-resistive		
Measuring range	0 ... 10 m		
Accuracy	± 0.25 % FS		
Resolution	1 mm		
Internal memory			
Capacity	9 MB (non-volatile)		
Communication interfaces	RS-232; SDI-12 or SDI-12 via RS-485; Modbus (optional)		
Maximum cable length			
RS-422/485	max. 500 m (9600 Baud)		
RS-232/SDI-12	max. 65 m (9600 Baud/1200 Baud)		
Operating temperature	-5 °C ... +35 °C		
Storage temperature	-20 °C ... +70 °C		
Protection class	IP 68		
Dimensions			
Length	45 ... 52.2 cm (depending on measuring frequency)		
Diameter	7.5 cm (cylindrical)		
Housing material	POM		
Plausibility check	through status information		

A.2 Information on electromagnetic compatibility

Applicable to the European Union:

CAUTION: The OTT SLD is a Class A product (acc. to EN 61326-1:2006). In a residential environment, the OTT SLD may create radio interference. In such a case, the user must take appropriate actions to eliminate such interference.

A.3 Firmware update

- Download a new version of the OTT SLD firmware from the www.ott.com website (file: e.g. "SLD_V341_Midlife.bin").
- Temporarily connect the OTT SLD to the PC using an RS-422/USB interface converter (accessory) (RS-422 four-wire connection), as shown in Fig. 5. The detailed wire assignment of the interface converter may be obtained from the supplement sheet supplied.
- Start the OTT SLD EasyUse software.
- Enable the "Service mode" of the OTT SLD EasyUse software by simultaneously pressing the keys "Ctrl + Alt + S".
- Check communication as described in Chapter 3.3. For cable lengths from 50 m long on, reduce the "Recorder/Upgrade baud rate" to 9600 baud.
- From the "Updates" menu, select the "Firmware Upgrade ..." option.
- Select the current update file and then click on the "Open" button.
- Select "OK" to confirm the safety question → The OTT SLD EasyUse software copies the new firmware into the OTT SLD.

Note

- ▶ The settings saved in the OTT SLD are not lost after an update. However, the measured values recorded will be lost!

Appendix B – SDI-12 Commands and Responses

B.1 Basic commands

All SDI-12 basic commands are implemented in the OTT SLD. The following SDI-12 basic commands are relevant to the operation of the OTT SLD:

Conventions applicable to measure value formats:

p – Sign (+,-)

b – Number before decimal point; output without leading zeros!

e – Number after decimal point

Command	Response	Description
a!	a<CR><LF>	Acknowledgement active a – Sensor address; factory setting = 0
aI!	allccccccmmmmmm vvvxxxxxx<CR><LF>	Send identification a – Sensor address 11 – SDI-12 protocol version ccccccc – Manufacturer's identification (company name) mmmmmm – Sensor identification vvv – Sensor version (firmware) xxxxxx – Serial number OTT SLD response = 012OTT HACHSLD340123456 (example)
aAb!	b<CR><LF>	Change sensor address a – Old sensor address b – New sensor address
?!	a<CR><LF>	Query sensor address a – Sensor address
▶ "Velocity" measuring mode		
aM!	atttn<CR><LF> and a<CR><LF> after ttt seconds	Start measurement: Velocity in x direction a – Sensor address ttt – Time in seconds until the sensor has determined the measurement result. OTT SLD response = averaging time set (average interval) + 4 seconds n – Number of measured values OTT SLD response = 9 a<CR><LF> – Service request
aD0!	a<value1><value2><value3><CR><LF>	Send data
aD1!	a<value4><value5><value6><CR><LF>	a – Sensor address
aD2!	a<value7><value8><value9><CR><LF>	<valuex> – Velocity in x direction Measuring cell 1 ... 9 [m/s] Measured value format: pbb.eee Range: -10.000 ... +10.000m/s
aM1!	atttn<CR><LF> and a<CR><LF> after 1 second	Start measurement: Water coverage, temperature, pitch, roll, quality values a – Sensor address ttt – Time in seconds until the sensor has determined the measurement result. OTT SLD response = 001; averaging time set (average interval) n – Number of measured values OTT SLD response = 9 a<CR><LF> – Service request

Command	Response	Description
aD0!	a<value1><value2><value3>... ...<value4><value5><CR><LF>	Send data a – Sensor address <value1> – Temperature [°C] Measured value format: pbb.ee Range: -6.00 ... +40.00°C <value2> – Combined water coverage from pressure measurement and acoustic measurement (pressure measurement specifies the range in which the OTT SLD evaluates the acoustic measurement) [m] Measured value format: pb.eee Range: +0 ... +9.999 m <value3> – Water coverage for acoustic measurement [m] Measured value format: pb.eee Range: +0 ... +9.999 m <value4> – Quality value for pressure measurement [counts] Measured value format: pbbb Range: +0 ... +255 counts <value5> – Quality value for acoustic measurement [counts] Measured value format: pbbb Range: +0 ... +255 counts
aD1!	a<value6><value7><value8>... ...<value9><CR><LF>	<value6> – "Pass" values for acoustic measurement [%] Measured value format: pbbb Range: +0 ... +100% <value7> – Water coverage for pressure measurement [dbar] Measured value format: pb.eee Range: +0 ... +9.999 dbar <value8> – Pitch (Position of the instrument in transverse axis) [0.1°] Measured value format: pbb Range: -25 ... +25° (outside → error bit) <value9> – Roll (Position of the instrument in longitudinal axis) [0.1°] Measured value format: pbb Range: -25 ... +25° (outside → error bit)
aM2!	atttn<CR><LF> and a<CR><LF> after 1 second	Beam 1: Read signal amplitudes of the last measurement a – Sensor address ttt – Time in seconds until the sensor has provided the measurement result. OTT SLD response = 001 n – Number of measured values OTT SLD response = 9 a<CR><LF> – Service request
aD0! aD1! aD2!	a<value1><value2><value3><CR><LF> a<value4><value5><value6><CR><LF> a<value7><value8><value9><CR><LF>	Send data a – Sensor address <valuex> – Beam 1: Signal amplitude Measuring cell 1 ... 9 [counts] Measured value format: pbbb Range: +0 ... +255 counts
aM3!	atttn<CR><LF> and a<CR><LF> after ttt seconds	Start measurement: Velocity in y direction a – Sensor address ttt – Time in seconds until the sensor has determined the measurement result. OTT SLD response = averaging time set (average interval) + 4 seconds n – Number of measured values OTT SLD response = 9 a<CR><LF> – Service request

Command	Response	Description
aD0!	a<value1><value2><value3><CR><LF>	Send data
aD1!	a<value4><value5><value6><CR><LF>	a – Sensor address
aD2!	a<value7><value8><value9><CR><LF>	<valuex> – Velocity in y direction Measuring cell 1 ... 9 [m/s] Measured value format: pbbb.eee Range: -10.000 ... +10.000m/s
aM4!	atttn<CR><LF> and a<CR><LF> after 1 second	Beam 2: Read signal amplitudes of the last measurement a – Sensor address ttt – Time in seconds until the sensor has provided the measurement result. OTT SLD response = 001 n – Number of measured values OTT SLD response = 9 a<CR><LF> – Service request
aD0!	a<value1><value2><value3><CR><LF>	Send data
aD1!	a<value4><value5><value6><CR><LF>	a – Sensor address
aD2!	a<value7><value8><value9><CR><LF>	<valuex> – Beam 2: Signal amplitude Measuring cell 1 ... 9 [counts] Measured value format: pbbbb Range: +0 ... +255 counts
aM7!	atttn<CR><LF> and a<CR><LF> after 1 second	Read error messages and status values a – Sensor address ttt – Time in seconds until the sensor has provided the measurement result. OTT SLD response = 001 n – Number of measured values OTT SLD response = 2 a<CR><LF> – Service request
aD0!	a<value1><value2><CR><LF>	Send data a – Sensor address <value1> – Refer to the description of the same <value2> – command in "Discharge" measuring mode
► "Discharge" measuring mode		
aM!	atttn<CR><LF> and a<CR><LF> after 1 second	Start measurement: Discharge, temperature, water coverage, k*A factor, average flow velocity, time spans, status value a – Sensor address ttt – Time in seconds until the sensor has determined the measurement result. OTT SLD response = averaging times set (average interval) from "Flow" and "Level" + 5 seconds n – Number of measured values OTT SLD response = 2 a<CR><LF> – Service request
aD0!	a<value1><value2><CR><LF>	Send data a – Sensor address <value1> – Currently calculated discharge value [m ³ /s] Measured value format: pbbbb Range: +0 ... +9999 m ³ /s <value2> – Currently calculated discharge value [l/s] Measured value format: pbbb Range: +0 ... +999 l/s

Command	Response	Description
aD1!	a<value3><value4><value5>... ...<value6><CR><LF>	Send data
aD2!	a<value7><value8><value9>... ...<CR><LF>	<p>a – Sensor address</p> <p><value3> – Temperature [°C] Measured value format: pb.b.ee Range: -6.00 ... +40.00°C</p> <p><value4> – Water coverage [m] Measured value format: pb.eee Range: +0.000 ... +9.999 m</p> <p><value5> – k*A factor [m²] Measured value format: pb.bbb.e Range: +0 ... +99999,0 m²</p> <p><value6> – Average flow velocity within the selected cell range [m/s] Measured value format: pb.eee Range: -9.999 ... +9.999m/s</p> <p><value7> – Time span between the last and current discharge measurement – for service purposes only!</p> <p><value8> – Time span up to the end of the measuring interval (accumulated discharge) – for service purposes only!</p> <p><value9> – Status value of the discharge measurement – for service purposes only!</p>
aM1!	atttn<CR><LF> and a<CR><LF> after 1 second	<p>Read accumulated discharge</p> <p>a – Sensor address</p> <p>ttt – Time in seconds until the sensor provides the measurement result. OTT SLD response = 001</p> <p>n – Number of measured values OTT SLD response = 8</p> <p>a<CR><LF> – Service request</p>
aD0!	a<value1><value2><value3>... ...<value4><CR><LF>	Send data
aD1!	a<value5><value6><value7>... ...<value8><CR><LF>	<p>Accumulated discharge:</p> <p><value1> – Partial value [10⁸m³] Measured value format: pb.bbb Range: +0 ... +9999 10⁸m³</p> <p><value2> – Partial value [10⁴m³] Measured value format: pb.bbb Range: +0 ... +9999 10⁴m³</p> <p><value3> – Partial value [m³] Measured value format: pb.bbb Range: +0 ... +9999 m³</p> <p><value4> – Partial value [l] Measured value format: pb.bbb Range: +0 ... +999 l</p> <p>Accumulated discharge of the last interval:</p> <p><value5> – Partial value [10⁸m³] Measured value format: pb.bbb Range: +0 ... +9999 10⁸m³</p> <p><value6> – Partial value [10⁴m³] Measured value format: pb.bbb Range: +0 ... +9999 10⁴m³</p> <p><value7> – Partial value [m³] Measured value format: pb.bbb Range: +0 ... +9999 m³</p> <p><value8> – Partial value [l] Measured value format: pb.bbb Range: +0 ... +999 l</p>

Command	Response	Description
aM2!	atttn<CR><LF> and a<CR><LF> after 1 second	Beam 1: Read signal amplitudes of the last measurement a – Sensor address ttt – Time in seconds until the sensor has provided the result. OTT SLD response = 001 n – Number of measured values OTT SLD response = 9 a<CR><LF> – Service request
aD0! aD1! aD2!	a<value1><value2><value3><CR><LF> a<value4><value5><value6><CR><LF> a<value7><value8><value9><CR><LF>	Send data a – Sensor address <valuex> – Beam 1: Signal amplitude Measuring cell 1 ... 9 [counts] Measured value format: pbbb Range: +0 ... +255 counts
aM3!	atttn<CR><LF> and a<CR><LF> after 1 second	Start measurement: Pitch, roll, pressure a – Sensor address ttt – Time in seconds until the sensor has determined the measurement result. OTT SLD response = 001 n – Number of measured values OTT SLD response = 3 a<CR><LF> – Service request
aD0!	a<value1><value2><value3>... ...<CR><LF>	Send data <value1> – Pitch (Position of the instrument in transverse axis) [0.1°] Measured value format: pbb.ee Range: -25.0 ... +25.0° <value2> – Roll (Position of the instrument in longitudinal axis) [0.1°] Measured value format: pbb.ee Range: -25.0 ... +25.0° <value3> – Water coverage for pressure measurement [dbar] Measured value format: pb.eee Range: +0 ... +9.999 dbar
aM4!	atttn<CR><LF> and a<CR><LF> after 1 second	Beam 2: Read signal amplitudes of the last measurement a – Sensor address ttt – Time in seconds until the sensor has provided the result. OTT SLD response = 001 n – Number of measured values OTT SLD response = 9 a<CR><LF> – Service request
aD0! aD1! aD2!	a<value1><value2><value3><CR><LF> a<value4><value5><value6><CR><LF> a<value7><value8><value9><CR><LF>	Send data a – Sensor address <valuex> – Beam 2: signal amplitude Measuring cell 1 ... 9 [counts] Measured value format: pbbb Range: +0 ... +255 counts
aM5!	atttn<CR><LF> and a<CR><LF> after 1 second	Read unfiltered velocity in x direction a – Sensor address ttt – Time in seconds until the sensor has provided the result. OTT SLD response = 001 n – Number of measured values OTT SLD response = 9 a<CR><LF> – Service request

Command	Response	Description
aD0!	a<value1><value2><value3><CR><LF>	Send data
aD1!	a<value4><value5><value6><CR><LF>	a – Sensor address
aD2!	a<value7><value8><value9><CR><LF>	<valuex> – Velocity in x direction Measuring cell 1 ... 9 [m/s] Measured value format: pbb.eee Range: -10.000 ... +10.000m/s
aM6!	atttn<CR><LF> and a<CR><LF> after 1 second	Read unfiltered velocity in y direction a – Sensor address ttt – Time in seconds until the sensor has provided the result. OTT SLD response = 001 n – Number of measured values OTT SLD response = 9 a<CR><LF> – Service request
aD0!	a<value1><value2><value3><CR><LF>	Send data
aD1!	a<value4><value5><value6><CR><LF>	a – Sensor address
aD2!	a<value7><value8><value9><CR><LF>	<valuey> – Velocity in y direction Measuring cell 1 ... 9 [m/s] Measured value format: pbb.eee Range: -10.000 ... +10.000m/s
aM7!	atttn<CR><LF> and a<CR><LF> after 1 second	Read error messages and status values a – Sensor address ttt – Time in seconds until the sensor has provided the result. OTT SLD response = 001 n – Number of measured values OTT SLD response = 2 a<CR><LF> – Service request
aD0!	a<value1><value2><CR><LF>	Send data a – Sensor address <value1> – Error messages; 8-bit binary word Example: "10000000" Bit 1 ... 8: 0 = O.K. Bit 1: For service purposes only Bit 2: 1 = Faulty measured values Bit 3: 1 = Faulty sensor data (temperature, pitch, roll, pressure) Bit 4: 1 = Instrument internal error Bit 5: 1 = Error in flash memory Bit 6: For service purposes only Bit 7: For service purposes only Bit 8: 1 = Background noise above allowable limit <value2> – Status values; 8-bit binary word Example: "01010000" Bit 1: Instrument orientation (for "Discharge" instrument version); 0 = Water level sensor directed upwards 1 = Water level sensor directed downwards Bit 2: For service purposes only Bit 3: 1 = Pitch outside the allowable value range of $\pm 25^\circ$ Bit 4: 1 = Roll outside the allowable value range of $\pm 25^\circ$ Bit 5 + Bit 6: 00 = Supply voltage too low, 01 = Power applied, 10 = Break, 11 = RTC alarm Bit 7 + Bit 8: Driving power at the sound transducer; 00 = 0 (high), 01 = 1, 10 = 2, 11 = 3 (low)

Command	Response	Description
aV!	atttn<CR><LF>	Perform system test a – Sensor address ttt – Time in seconds until the sensor provides the result of the system test. OTT SLD response = 000 n – Number of result values from system test OTT SLD response = 0 a<CR><LF> – Service request
aD0!	a<CR><LF>	Send data (after aV!) a<CR><LF> – Service request The OTT SLD does not perform the system test!

For more information on the SDI-12 basic commands, please refer to the publication SDI-12; "A Serial-Digital Interface Standard for Microprocessor-Based Sensors; Version 1.2" (refer to the website "www.sdi-12.org").

B.2 Advanced SDI-12 commands

There are no SDI-12 advanced commands implemented in the OTT SLD.

Appendix C – OTT SLD and Modbus fieldbus protocol

Using a protocol converter, the OTT SLD may be connected to a fieldbus system featuring RS-485 interfaces and Modbus protocol. For this purpose, OTT offer the UNIGATE® CL-RS protocol converter as an accessory, which provides the necessary script programming.

Fig. 32: Connecting the side looking Doppler OTT SLD to the UNIGATE® CL-RS protocol converter via RS-485 interface.

The GND connection represented by the dashed line is necessary only in case the protocol converter and the OTT netDL are powered by separate power supplies.

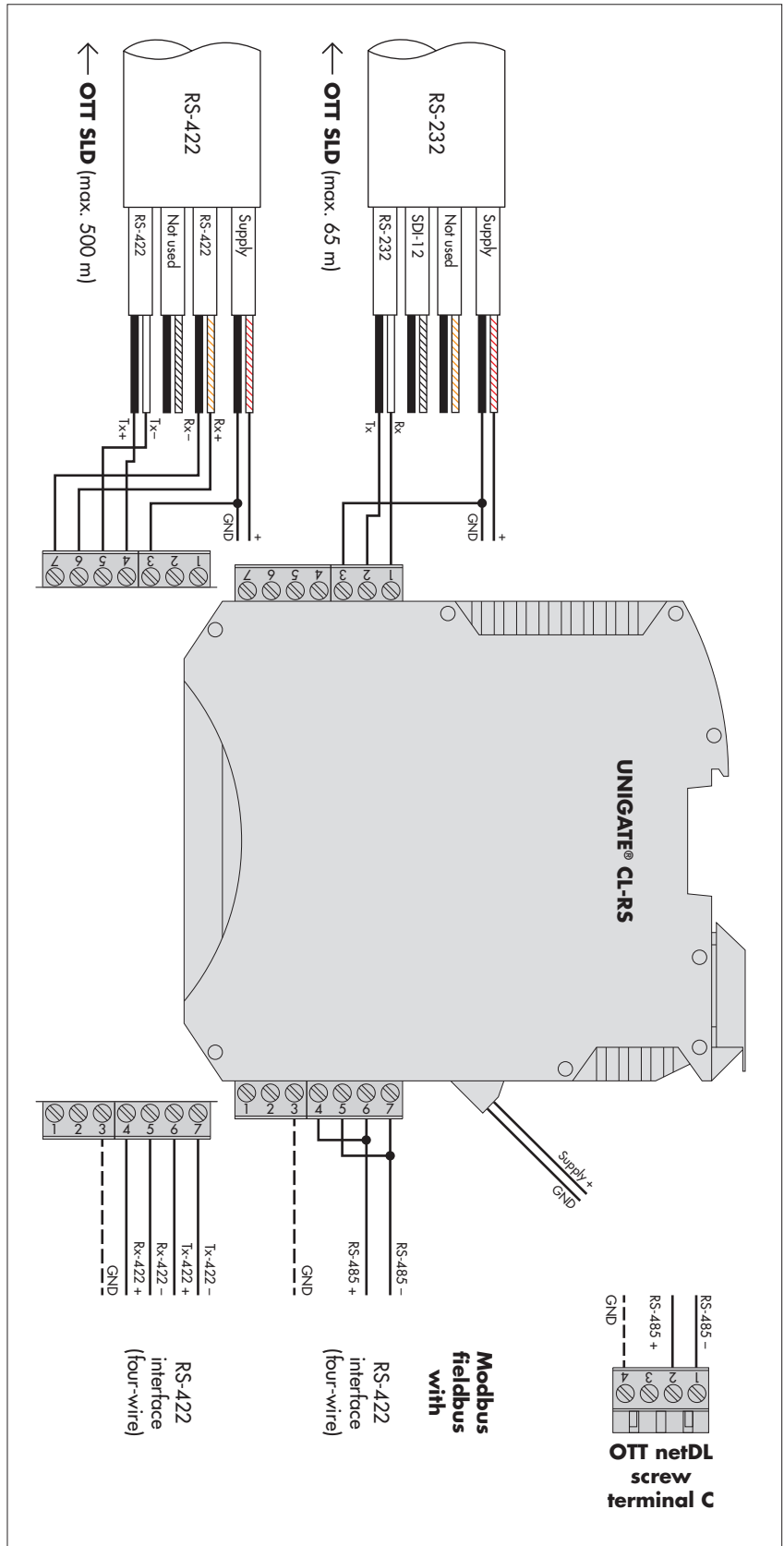

Installing the UNIGATE® CL-RS protocol converter

The UNIGATE® CL-RS is designed to be installed onto a standard C rail (TS 35). The electrical connections are to be made as shown in Figure 32. The fieldbus system must be fitted with terminators at the front and back ends of the bus line. For this purpose, two slide switches are provided to connect one terminator (RS-422) / two terminators (RS-485) (for RS-485 (two-wire configuration): Rx-422 → OFF; Tx-422 → ON).

Basic settings for Modbus operation

- ▶ Measuring mode: (0x03) Read Holding Registers
- ▶ Baud rate: 9600 bit/s
- ▶ Data bits: 8
- ▶ Parity: N
- ▶ Stop bits: 1

Modbus address assignment

Use the rotary switches "S6" and "S7" to select a Modbus address between 0 and 255. It is a hexadecimal setting in which S6 is the high nibble and S7 is the low nibble. Modbus addresses 0 (Broadcast) and 248 to 255 (reserved for internal purposes) must not be used.

Example: S6 = 1; S7 = 2 → 0x12 → Modbus address 18.

Please note: Set the Modbus address only with power supply switched off!
(Any address change will be effective only after "PowerOn Reset" of the protocol converter.)

Register allocation

- ▶ Velocity values:

Address	Data type	Description
0	Word	High byte: Minutes Low byte: Seconds
1	Word	High byte: Day Low byte: Hour
2	Word	High byte: Year Low byte: Month
3	Short	Error code
4	Short	Temperature [0.01°C]
5	Unsigned short	Battery voltage [0.1 V]
6	Unsigned short	Speed of sound [0.1 m/s]
7	Unsigned char	Status
8	Unsigned short	Not used
9	Unsigned short	Not used
10	Short	Velocity: x direction, cell #1 [mm/s]
11	Short	Velocity: x direction, cell #2 [mm/s]
12	Short	Velocity: x direction, cell #3 [mm/s]
13	Short	Velocity: x direction, cell #4 [mm/s]
14	Short	Velocity: x direction, cell #5 [mm/s]
15	Short	Velocity: x direction, cell #6 [mm/s]
16	Short	Velocity: x direction, cell #7 [mm/s]
17	Short	Velocity: x direction, cell #8 [mm/s]
18	Short	Velocity: x direction, cell #9 [mm/s]
19	Short	Velocity: y direction, cell #1 [mm/s]
20	Short	Velocity: y direction, cell #2 [mm/s]
21	Short	Velocity: y direction, cell #3 [mm/s]
22	Short	Velocity: y direction, cell #4 [mm/s]
23	Short	Velocity: y direction, cell #5 [mm/s]
24	Short	Velocity: y direction, cell #6 [mm/s]
25	Short	Velocity: y direction, cell #7 [mm/s]
26	Short	Velocity: y direction, cell #8 [mm/s]
27	Short	Velocity: y direction, cell #9 [mm/s]

28	Unsigned char	Signal amplitude: Beam #1, cell #1 [counts]
29	Unsigned char	Signal amplitude: Beam #1, cell #2 [counts]
30	Unsigned char	Signal amplitude: Beam #1, cell #3 [counts]
31	Unsigned char	Signal amplitude: Beam #1, cell #4 [counts]
32	Unsigned char	Signal amplitude: Beam #1, cell #5 [counts]
33	Unsigned char	Signal amplitude: Beam #1, cell #6 [counts]
34	Unsigned char	Signal amplitude: Beam #1, cell #7 [counts]
35	Unsigned char	Signal amplitude: Beam #1, cell #8 [counts]
36	Unsigned char	Signal amplitude: Beam #1, cell #9 [counts]
37	Unsigned char	Signal amplitude: Beam #2, cell #1 [counts]
38	Unsigned char	Signal amplitude: Beam #2, cell #2 [counts]
39	Unsigned char	Signal amplitude: Beam #2, cell #3 [counts]
40	Unsigned char	Signal amplitude: Beam #2, cell #4 [counts]
41	Unsigned char	Signal amplitude: Beam #2, cell #5 [counts]
42	Unsigned char	Signal amplitude: Beam #2, cell #6 [counts]
43	Unsigned char	Signal amplitude: Beam #2, cell #7 [counts]
44	Unsigned char	Signal amplitude: Beam #2, cell #8 [counts]
45	Unsigned char	Signal amplitude: Beam #2, cell #9 [counts]

► Water coverage values:

Address	Data type	Description
46	Short	Pitch [0.1°]
47	Short	Roll [0.1°]
48	Unsigned short	Water coverage for pressure measurement [mm]
49	Short	Water coverage for acoustic measurement [mm]
50	Unsigned short	Quality value for acoustic measurement [counts]
51	Unsigned short	Speed of sound [0.1 m/s]
52	Short	Combined water coverage from pressure measurement and acoustic measurement (pressure measurement specifies the range in which the OTT SLD evaluates the acoustic measurement) [mm]
53	–	Not used
54	–	Not used
55	Short	"Pass" values for acoustic measurement [%]
56	Short	Temperature [0.01°C]

► Discharge values:

Address	Data type	Description
57	Word	Addresses 58 ... 60: Date and time of the currently calculated discharge value High byte: Minutes Low byte: Seconds
58	Word	High byte: Day Low byte: Hour
59	Word	High byte: Year Low byte: Month
60	Unsigned short	Currently calculated discharge value, the two MSBs of a 32-bit value [l/s]
61	Unsigned short	Currently calculated discharge value, the two LSBs of a 32-bit value [l/s]
62	Unsigned short	Accumulated discharge value, the two MSBs of a 48-bit value [l]
63	Unsigned short	Accumulated discharge value, the two CSBs of a 48-bit value [l]
64	Unsigned short	Accumulated discharge value, the two LSBs of a 48-bit value [l]

Please note!

After having connected the UNIGATE CL-RS protocol converter to the OTT SLD, you have to start the OTT SLD operation mode "On-Line Data Collection" during commissioning:

- Select the "Start Data Collection" option from the "On-line" menu of the OTT SLD EasyUse Software.

Appendix D – Representation of the discharge values in "Discharge measurement" measuring mode

The measured values for instantaneous discharge as well as the accumulated discharge values may take large to very large numerical values. Therefore, the OTT SLD splits the measured values into partial amounts that are weighed differently. In the evaluation unit (alternatively in the datalogger as far as it is able to handle value ranges in the magnitude required), these numerical values then have to be "reassembled" according to the mathematical algorithms given below.

D.1 Representation in SDI-12 protocol

► Instantaneous discharge

Example: $Q_{inst} = 2\,512.345 \text{ m}^3/\text{s} = 2\,512\,345 \text{ l/s}$

Split into two partial amounts in the **aD0!** response to the **aM!** command:

– **<value1>**: $2\,512 \text{ m}^3/\text{s}$ (10^3 l/s)
 – **<value2>**: 345 l/s ($10^{-3} \text{ m}^3/\text{s}$)

$$\begin{aligned} Q_{inst} &= \langle\text{value1}\rangle + \langle\text{value2}\rangle \times 10^{-3} [\text{m}^3] \\ &= 2\,512 + 345 \times 10^{-3} \text{m}^3/\text{s} \\ &= 2\,512 + 0.345 \text{ m}^3/\text{s} \\ &= 2\,512.345 \text{ m}^3/\text{s} \end{aligned}$$

► Accumulated discharge and accumulated discharge from the last interval

Example: $Q_{inst}^* = 2\,500 \text{ m}^3/\text{s} = 2\,500\,000 \text{ l/s}$ $Q_{accumulated/24h} = 24 \text{ h} \times 3\,600 \text{ s/h} \times 2\,500\,000 \text{ l/s} = 217\,066\,608\,000 \text{ l}$

Split into four partial amounts in the **aD0!** and **aD1!** responses to the **aM1!** command (**aD0!**: values 1 ... 4; accumulated discharge; **aD1!**: values 5 ... 8; accumulated discharge from last interval):

– **<value1>**: $2 \times 10^8 \text{ m}^3$ ($\times 10^{11} \text{ l}$)
 – **<value2>**: $1\,706 \times 10^4 \text{ m}^3$ ($\times 10^7 \text{ l}$)
 – **<value3>**: $6\,608 \text{ m}^3$ ($\times 10^3 \text{ l}$)
 – **<value4>**: 0 l ($\times 10^{-3} \text{ m}^3$)

$$\begin{aligned} Q_{accumulated/24h} &= \langle\text{value1}\rangle \times 10^{11} + \langle\text{value2}\rangle \times 10^7 + \langle\text{value3}\rangle \times 10^3 + \langle\text{value4}\rangle [l] \\ &= 2 \times 10^{11} + 1\,706 \times 10^7 + 6\,608 \times 10^3 + 0 \text{ l} \\ &= 200\,000\,000\,000 + 17\,060\,000\,000 + 6\,608\,000 + 0 \text{ l} \\ &= 217\,066\,608\,000 \text{ l} \end{aligned}$$

or

$$\begin{aligned} Q_{accumulated/24h} &= ((\langle\text{value1}\rangle \times 10^4 + \langle\text{value2}\rangle) \times 10^4 + \langle\text{value3}\rangle) \times 10^3 + \langle\text{value4}\rangle [l] \\ &= ((2 \times 10^4 + 1\,706) \times 10^4 + 6\,608) \times 10^3 + 0 \text{ l} \\ &= (21\,706 \times 10^4 + 6\,608) \times 10^3 + 0 \text{ l} \\ &= 217\,066\,608 \times 10^3 + 0 \text{ l} \\ &= 217\,066\,608\,000 \text{ l} \end{aligned}$$

* Assumption in example: Q_{inst} is constant.

D.2 Representation in Modbus protocol

► Instantaneous discharge

Example: $Q_{inst} = 2\,512.345 \text{ m}^3/\text{s} = 2\,512\,345 \text{ l/s}$

Decimal 2 512 345 l → 0x26 55d9 l

Split into two partial amounts in one Modbus register each:

– Reg 60: 0x26 → Decimal 38 → Binary 0000000000100110

– Reg 61: 0x55d9 → Decimal 21 977 → Binary 0101010111011001

$$\begin{aligned} Q_{inst} &= \text{reg 60} \times 2^{16} + \text{reg 61} \text{ [l/s]} \\ &= 38 \times 2^{16} + 21\,977 \text{ l/s} \\ &= 2\,490\,368 + 21\,977 \text{ l/s} \\ &= 2\,512\,345 \text{ l/s} \end{aligned}$$

or

$$\begin{aligned} Q_{inst} &= \text{reg 60} \ll 16 \vee^{**} \text{reg 61} \text{ [l/s]} \\ &= \underset{32}{0000000000100110} \vee \underset{17}{0101010111011001} \underset{16}{\text{ l/s}} \\ &= \underset{32}{00000000001001100101010111011001} \underset{1}{\text{ l/s}} \\ &= 2\,512\,345 \text{ l/s} \end{aligned}$$

\ll = Shift operator to left-hand side: The bits are to be moved to left-hand side by the number of digits specified.

► Accumulated discharge

Example: $Q_{inst}^* = 2\,500 \text{ m}^3/\text{s} = 2\,500\,000 \text{ l/s}$ $Q_{accumulated/24h} = 24 \text{ h} \times 3\,600 \text{ s/h} \times 2\,500\,000 \text{ l/s} = 217\,066\,608\,000 \text{ l}$

Decimal 217 066 608 000 l → 0x32 8A2D 9580 l

Split into three partial amounts in one Modbus register each:

– Reg 62: 0x32 → Decimal 50 → Binary 0000000000110010

– Reg 63: 0x8A2D → Decimal 35 373 → Binary 1000101000101101

– Reg 64: 0x9580 → Decimal 38 272 → Binary 1001010110000000

$$\begin{aligned} Q_{accumulated/24h} &= \text{reg 62} \times 2^{32} + \text{reg 63} \times 2^{16} + \text{reg 64} \text{ [l]} \\ &= 50 \times 2^{32} + 35\,373 \times 2^{16} + 38\,272 \text{ l} \\ &= 214\,748\,364\,800 + 2\,318\,204\,928 + 38\,272 \text{ l} \\ &= 217\,066\,608\,000 \text{ l} \end{aligned}$$

or

$$\begin{aligned} Q_{accumulated/24h} &= ((\text{reg 62} \times 2^{16}) + \text{reg 63}) \times 2^{16} + \text{reg 64} \text{ [l]} \\ &= ((50 \times 2^{16}) + 35\,373) \times 2^{16} + 38\,272 \text{ l} \\ &= (3\,276\,800 + 35\,373) \times 65\,536 + 38\,272 \text{ l} \\ &= 3\,312\,173 \times 65\,536 + 38\,272 \text{ l} \\ &= 217\,066\,608\,000 \text{ l} \end{aligned}$$

or

$$\begin{aligned} Q_{accumulated/24h} &= \text{reg 62} \ll 32 \vee^{**} \text{reg 63} \ll 16 \vee \text{reg 64} \\ &= \underset{48}{0000000000110010} \vee \underset{33}{1000101000101101} \underset{32}{\vee} \underset{17}{1001010110000000} \underset{16}{\text{ l}} \\ &= \underset{48}{000000000011001010001010001011011001010110000000} \\ &= 217\,066\,608\,000 \text{ l} \end{aligned}$$

\ll = Shift operator to left-hand side: The bits are to be moved to left-hand side by the number of digits specified.

* Assumption in example: Q_{inst} is constant.

** Logical operator OR

Appendix E – Installation examples

The way how the OTT SLD is installed in a waterbody strongly depends on the local conditions. Installing the unit requires individual planning, based on the particular station. For installing the unit, OTT offer various stainless steel brackets and slide systems.

The following installation examples provide information on various installation options for an OTT SLD.

Sensor may be removed out of the water for service	OTT SLD type
▶ Example #1 – Installation at a staircase for water level measurement (mounting rail with slide)	Horizontal
▶ Example #2 – Installation at a staircase for water level measurement (dual T rail with roller slide)	Horizontal
▶ Example #3 – Installation at a natural river bank slope (mounting rail with slide)	Horizontal
▶ Example #4 – Installation at a vertical edge wall (mounting rail with slide)	Horizontal or vertical
Sensor is fixed	
▶ Example #5 – Installation on a concrete base in the river bed	Horizontal
▶ Example #6 – Installation at a sheet pile	Vertical
▶ Example #7 – Installation at a vertical edge wall (mounting plate)	Horizontal or vertical

E.1 Example #1 - Installation at a staircase for water level measurement (mounting rail with slide)

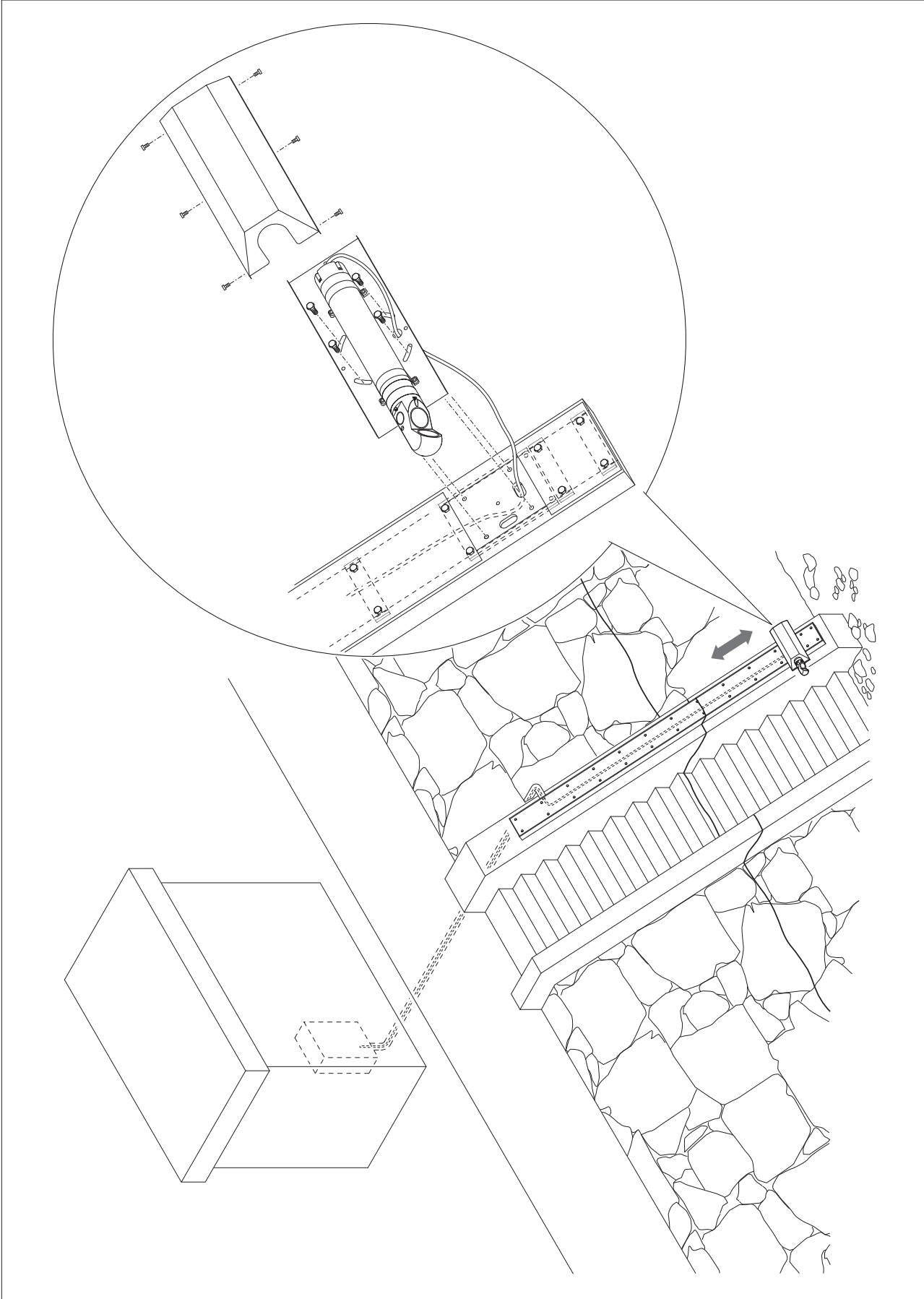

E.2 Example #2 - Installation at a staircase for water level measurement (dual T rail with roller slide)

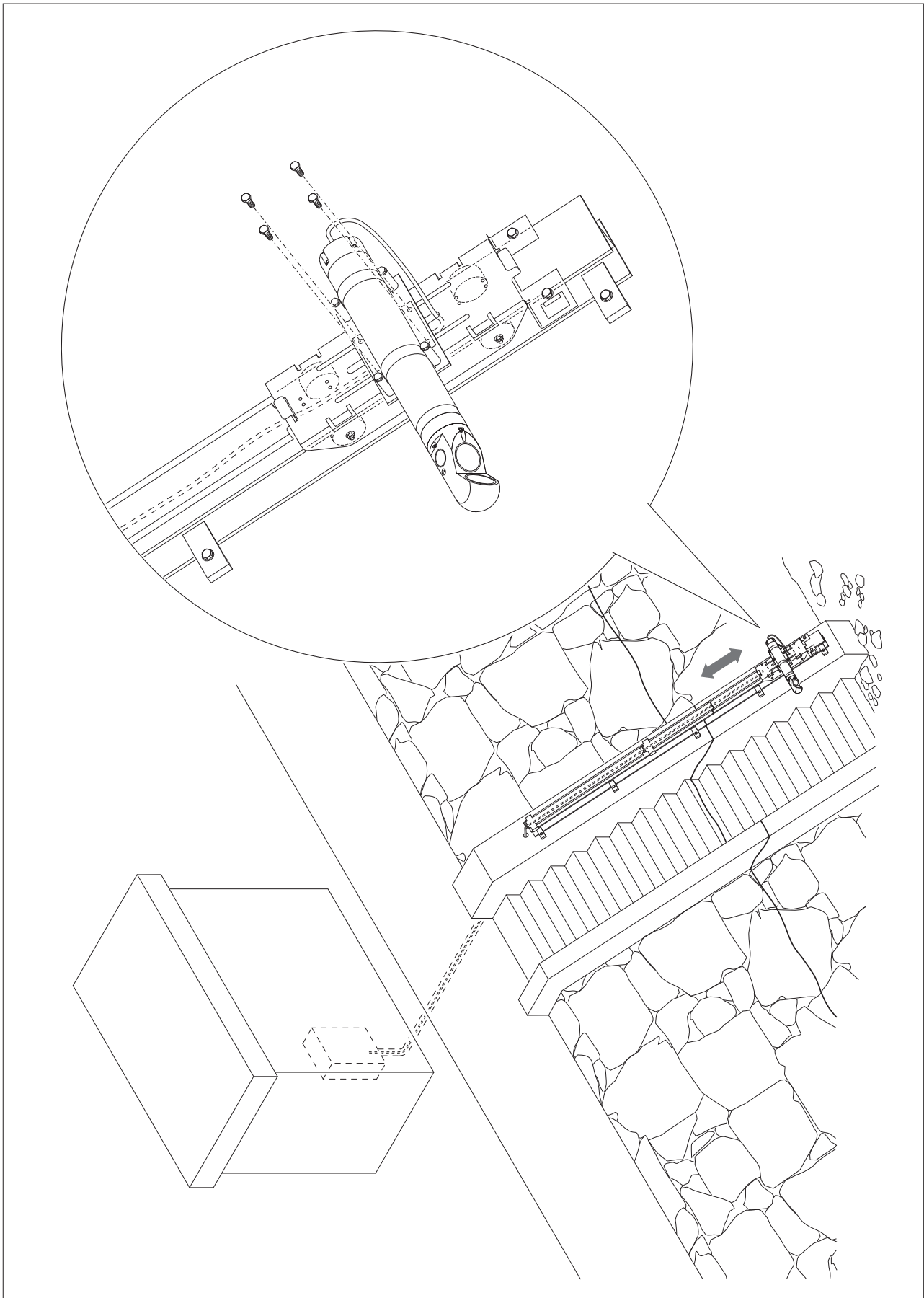

E.3 Example #3 - Installation at a natural river bank slope (mounting rail with slide)

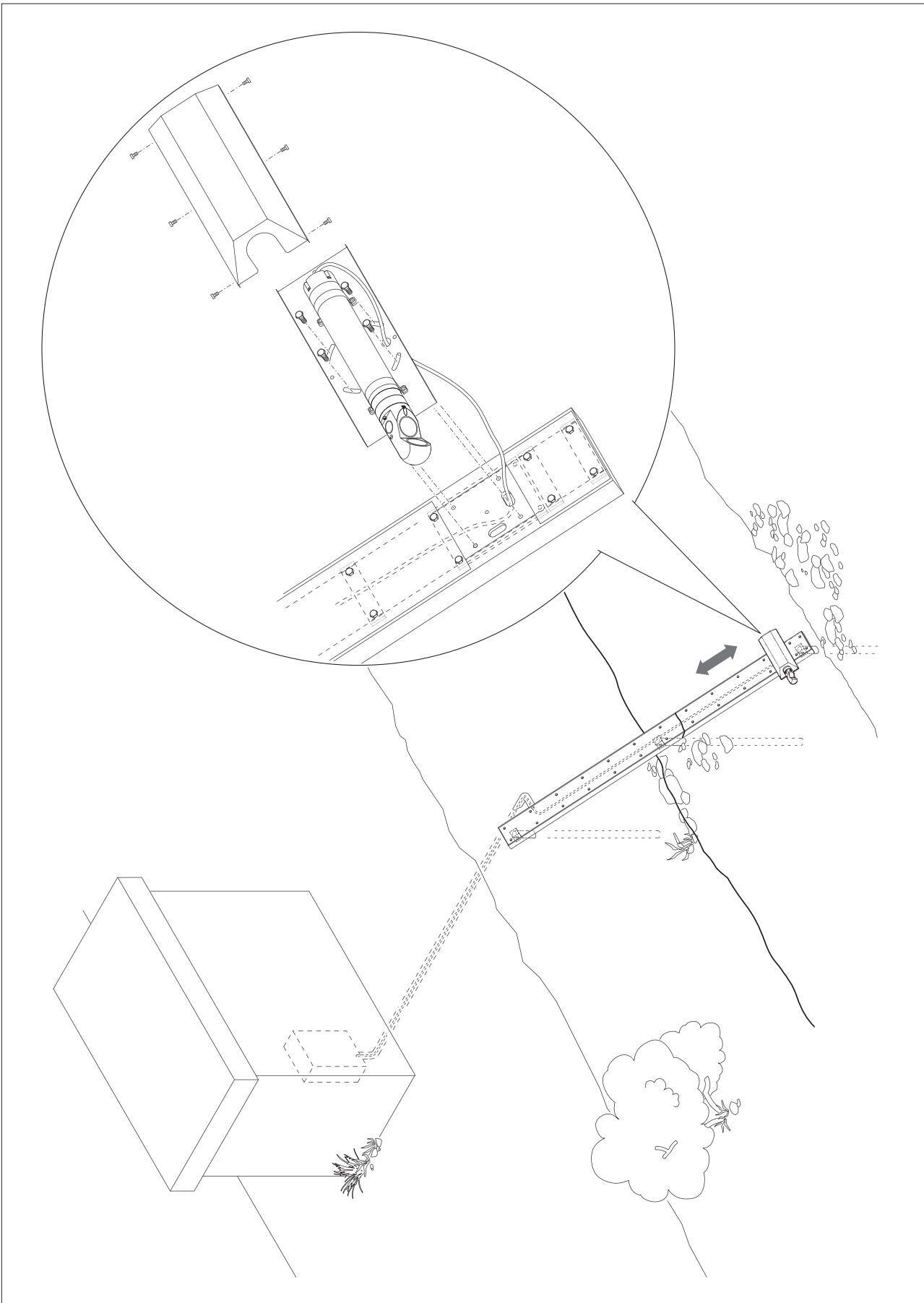

E.4 Example #4 - Installation at a vertical edge wall (mounting rail with slide)

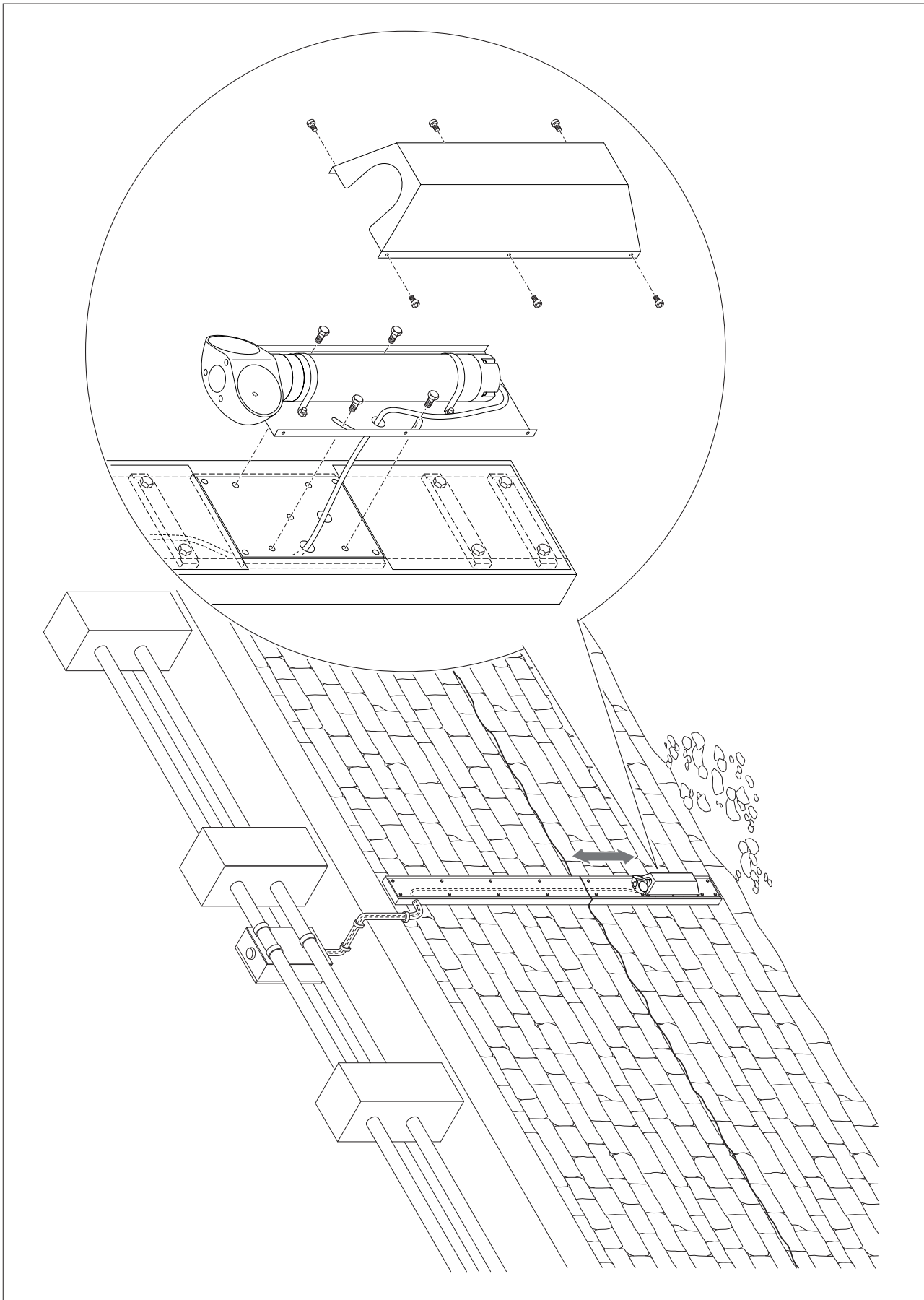

E.5 Example #5 - Installation on a concrete base in the river bed

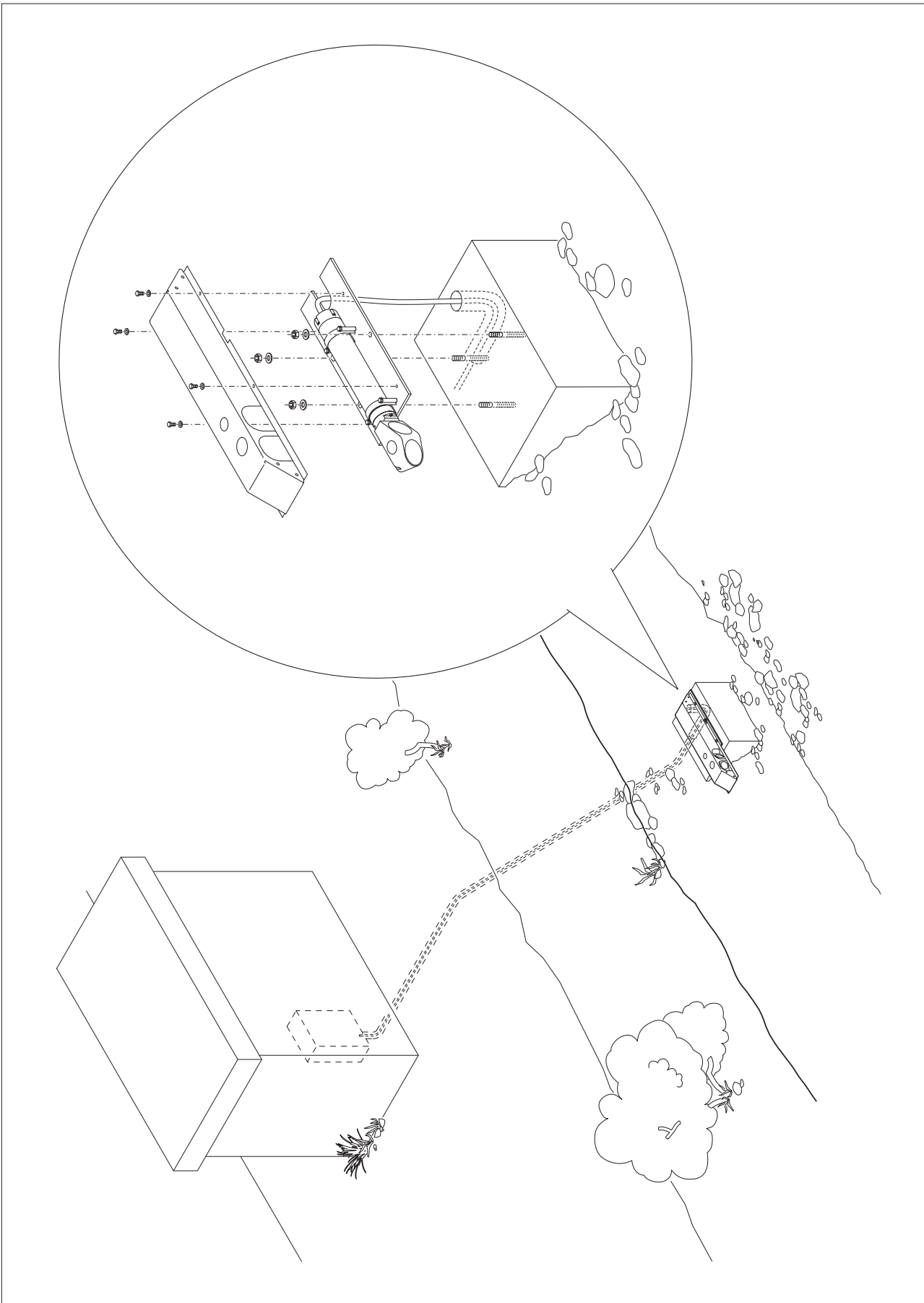

E.6 Example #6 - Installation at a sheet pile

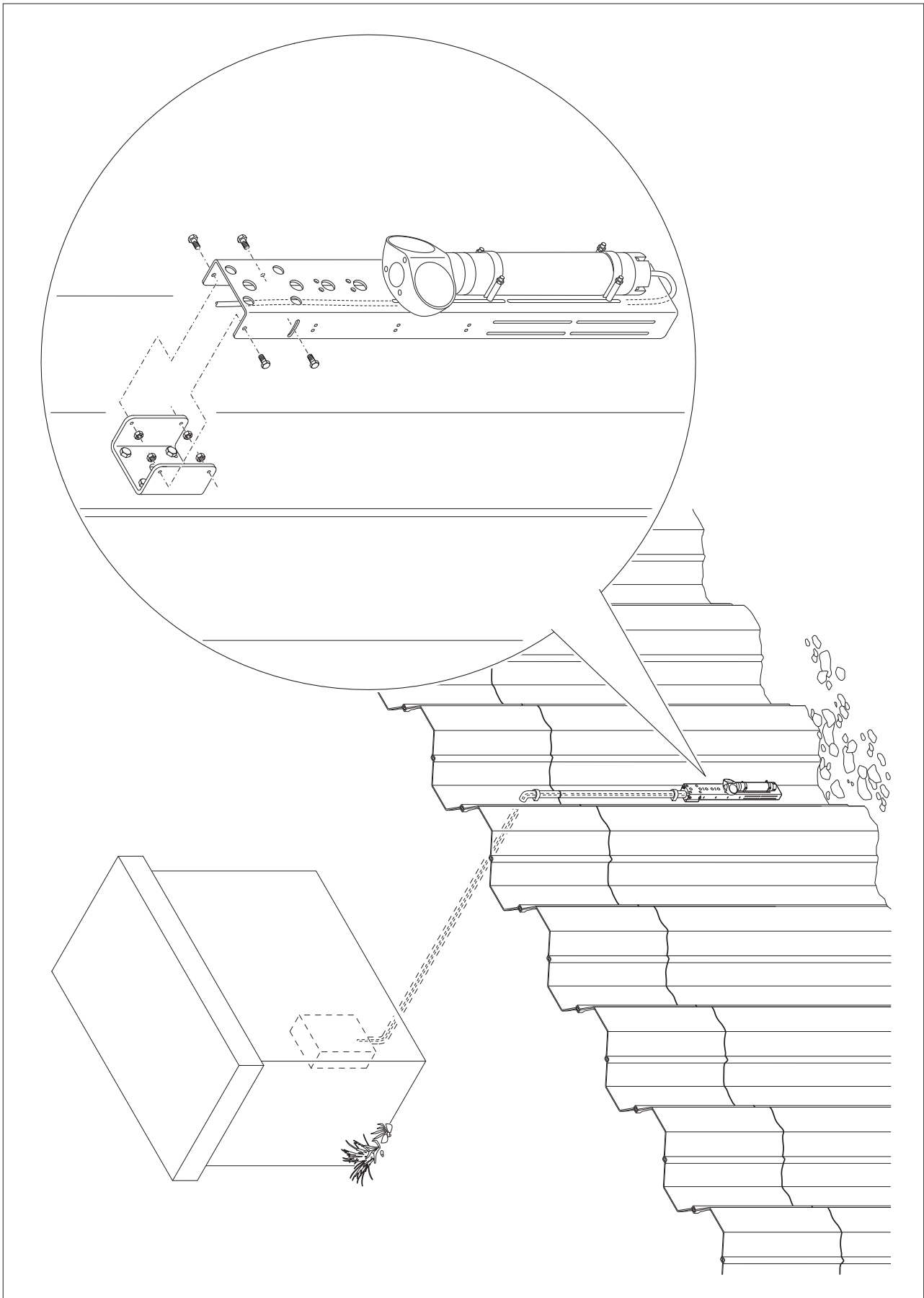

E.7 Example #7 - Installation at a vertical edge wall (mounting plate)

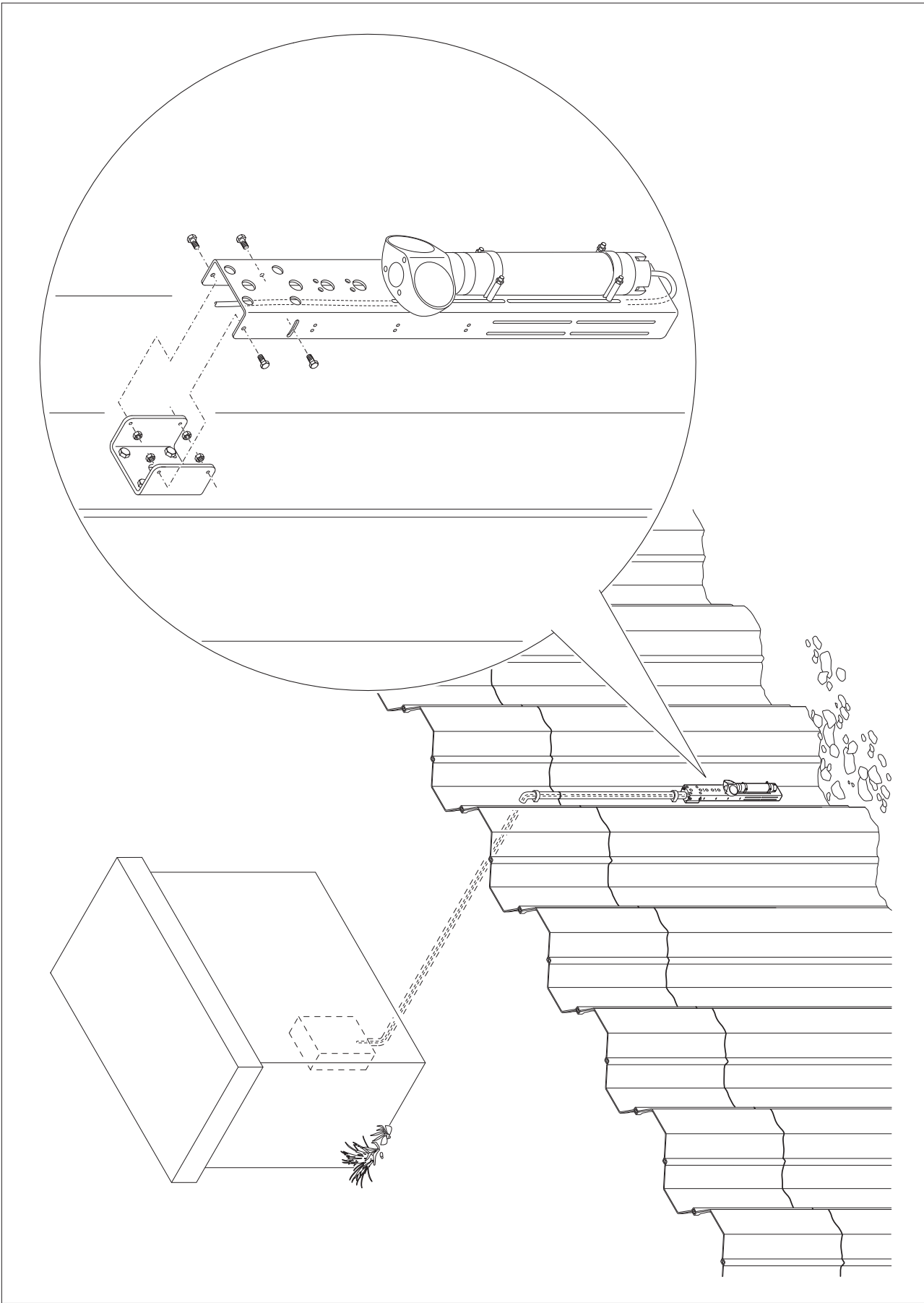

Document number
22.330.001.K.E 08-1214



OTT Hydromet GmbH

Ludwigstrasse 16
87437 Kempten · Germany
Phone +49 831 5617-0
Fax +49 831 5617-209

info@ott.com · www.ott.com