



# Turbidity Plus™

with Integrated Wiper

## User's Manual



June 23, 2017  
P/N 998-2187  
Revision D

**TURNER DESIGNS**  
1995 N. 1<sup>st</sup> Street  
San Jose, CA 95112  
Phone: (408) 749-0994  
FAX: (408) 749-0998

# Turbidity Plus Sensor

## Table of Contents

<b>1. Introduction</b>	
1.1 Description	4
<b>2. Inspection and Setup</b>	
2.1 Housing Configurations	5
2.2 Optional Accessories	5
2.3 Functional Test for Turbidity Plus with connector	5
2.4 Functional test of the wiper for the Turbidity Plus with connector	6
<b>3. Calibration</b>	
3.1 Direct Concentration Calibration for Turbidity Plus	8
<b>4. Integration</b>	
4.1 To take measurements	10
4.2 To trigger wiper	10
<b>5. Maintenance and Warranty</b>	
5.1 Maintenance	11
5.1.1 Rinsing	11
5.1.2 Care for the bulkhead connector	11
5.1.3 Cleaning the Optics	11
5.2 Warranty Terms	11
5.3 Warranty Service	11
5.4 Out of Warranty Service	12
<b>Appendices</b>	
A Specifications	14
B Recommended Measurement Practices	15
C Pigtail Cable and Connector Information	16
D Functional Test for Turbidity Plus with no Connector	17

## Turbidity Plus Sensor



### **WASTE ELECTRICAL AND ELECTRONIC EQUIPMENT (WEEE) DIRECTIVE**

Turner Designs is in the business of designing and selling products that benefit the well-being of our environment. Accordingly, we are concerned with preserving the surroundings wherever our instruments are used and happy to work with customers by complying with the WEEE Directive to reduce the environmental impact resulting from the use of our products.

#### **WEEE Return Process:**

To arrange the return of an end-of-life product, proceed as follows:

If you purchased your instrument through a Turner Designs Distributor please contact your local representative. They will instruct you where to return the end-of-life product.

If you purchased your instrument directly from Turner Designs please contact Turner Designs Customer Service

By Phone: 1-408-212-4041 or Toll Free: (877) 316.8049

By Email: Customer Service at [support@turnerdesigns.com](mailto:support@turnerdesigns.com)

Turner Designs will provide a WEEE RMA Number, a Shipping Account Number, and a Ship to Address. Package and ship the product back to Turner Designs.

The product will be dealt with per Turner Designs' end-of-life recycling program in an environmentally friendly way.

# Turbidity Plus Sensor

## 1. Introduction

---

### 1.1 Description

Turbidity Plus™ is an accurate single-channel turbidity sensor with an integrated, user-controlled wiper motor. It is designed for integration with multiparameter systems and dataloggers from which it receives power and wiper motor triggers at user-defined intervals. Turbidity Plus delivers a voltage output proportional to the turbidity of the sample which can be correlated to nephelometric turbidity unit (NTU) concentrations by calibrating the sensor using AMCO Clear Turbidity Standards available from GFS Chemicals. Deployable to 200 meters, Turbidity Plus is available with or without a plastic housing to facilitate integration.

# Turbidity Plus Sensor

## 2. Inspection and Setup

---

2.1 The Turbidity Plus Sensor is available in the following configurations:

- Turbidity Plus Sensor with Integrated Wiper P/N 2180-000
  - Fully configured with connector and complete wiper assembly
- Turbidity Plus with Integrated Wiper Motor and Wiper Assembly, No Connector P/N: 2180-000-NC.
- Turbidity Plus with Integrated Wiper Motor, No Wiper Assembly, No Connector P/N: 2180-000-NCW
- Turbidity Plus with Integrated Wiper Motor and Wiper Assembly, No Housing P/N: 2180-000-NH
- Turbidity Plus with Integrated Wiper Motor, No Wiper Assembly, No Housing, P/N: 2180-000-NHW

**Note:** *The wiper shaft has a flat edge for the application of a set screw to avoid unwanted movement of the wiper assembly.*

2.2 Optional Accessories:

Turbidity Plus 8-pin Pigtail Cables with Locking Sleeve, see Appendix C for more information.

- 0.6 meter Pigtail Cable with Locking Sleeve P/N 2200-170
- 5 meter Pigtail Cable with Locking Sleeve P/N 105-0552
- 10 meter Pigtail Cable with Locking Sleeve P/N 105-0555



# Turbidity Plus Sensor

**Note: Wire colors shown in steps 2.3 and 2.4 correlate to P/N's 2200-170, 105-0552, and 105-0555. Third party cables may not have the same color configuration. Turbidity Plus without connector refer to Appendix D.**

## 2.3 Functional test for Turbidity Plus with connector

To perform a functional check on Turbidity Plus, connect the Pigtail colored wires to the power supply and multi-meter as shown in Figure 1 below.

Additional Equipment required for functional tests:

DC Power Supply: 6 - 9 VDC, >100 mA

Multi-meter to read: 0 – 5 VDC



**Note: Supply voltages greater than 9 VDC will result in damage to the sensor.**

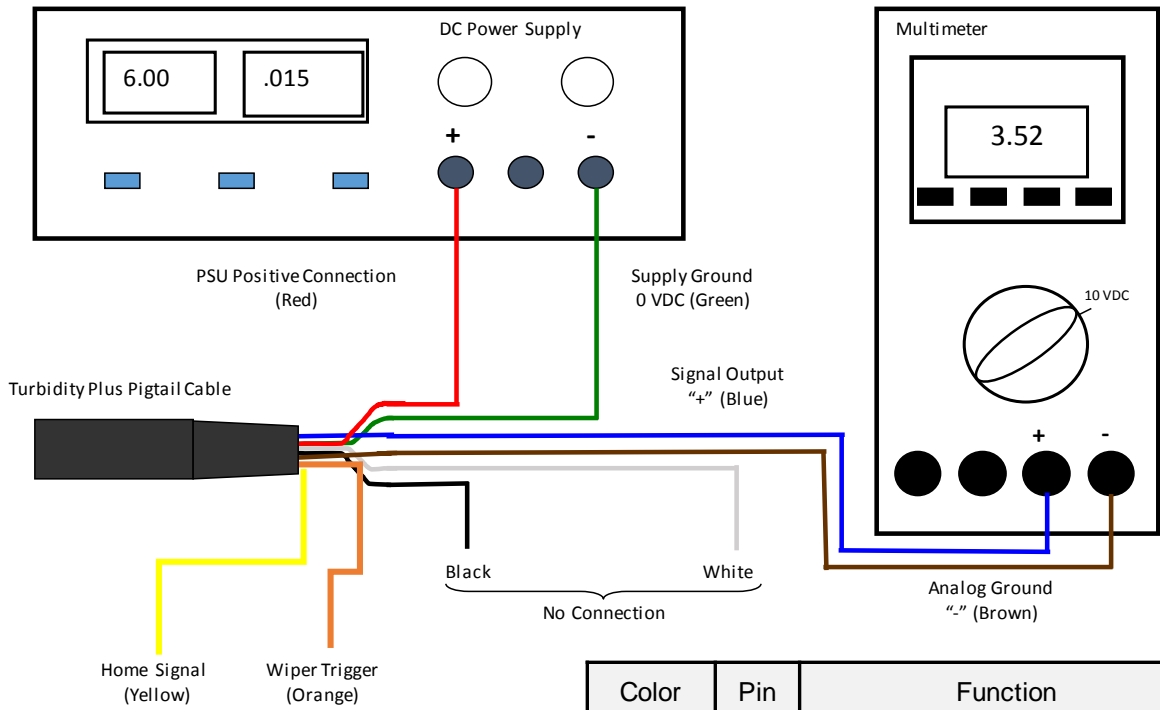

Color	Pin	Function
Black	1	N/A
White	2	N/A
Red	3	Supply Voltage 6-9 VDC
Green	4	Supply Ground 0 VDC
Blue	5	Signal Out "+", 0-5 VDC
Brown	6	Signal Ground, "-", 0 VDC
Yellow	7	Home Signal
Orange	8	Wiper Trigger, 3.2 VDC

Figure 1.

## Turbidity Plus Sensor

With Turbidity Plus connected as shown in Figure 1 perform functional tests to answer the following questions:

1. Is there voltage output?  
The multi-meter should be reading some voltage  $>0$  VDC
2. Does the voltage output change?  
Move the palm of your hand towards the optical head and check if the voltage output increases

**Note: A visual test of the LED for Turbidity Plus is not possible because it is IR, which is not visible.**

### 2.4 Functional test of the wiper for Turbidity Plus with connector

To perform a functional check on the wiper, connect the Pigtail colored wires to the power supply and multi-meter following the steps below, shown in Figure 2.

1. Disconnect the blue wire from the meter and connect the yellow wire in its place. It should read about 0 volts.
2. Briefly touch the orange wire to the power supply ground.
3. The wiper should start rotating and the meter should read about 3.2 volts until the wiper returns to its home position.

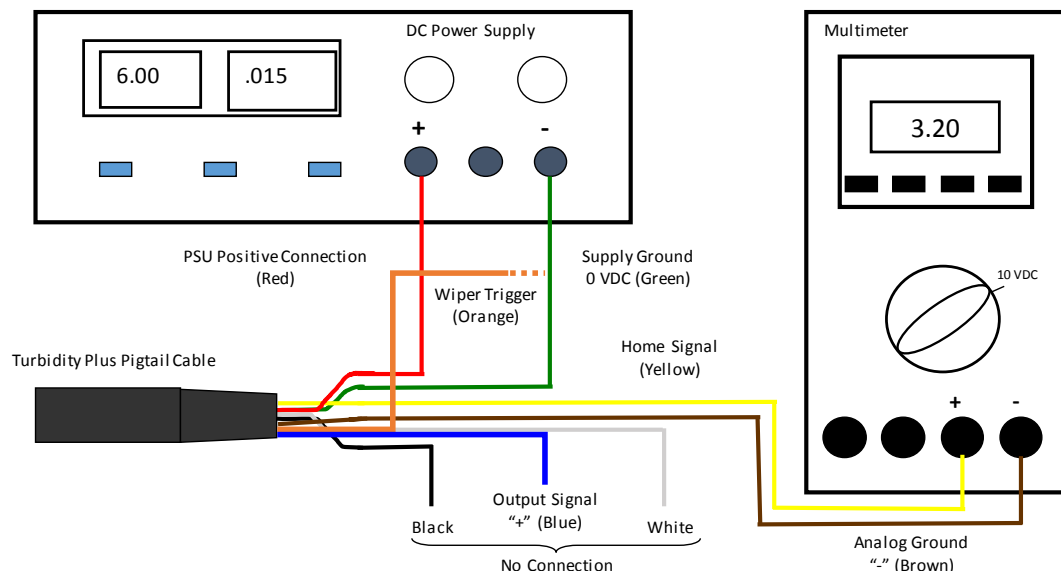

Figure 2.

**Note: The sensor has built in protection if the wiper becomes blocked and cannot move. In this case the wipe will stop and will try to return to the home position the next time it is triggered.**

**Warning: Do not move the wiper by hand. This can cause permanent damage to the sensor.**

## Turbidity Plus Sensor

### 3. Calibration

---

**Note: To make accurate and repeatable measurements it is important to keep the sensor clean; see Section 5.1 for information on cleaning your sensor. Refer to Appendix B - Recommended Measurement Practices.**

#### 3.1 Direct Concentration Calibration

Calibrating Turbidity Plus is a simple process that requires calibration standards to create a correlation factor which is used to convert raw voltage data to NTU concentrations.

Turner Designs recommends Amco Clear Turbidity Standards. They are non-toxic safe solutions consisting mainly of deionized water that come prepared in a broad range of concentrations and have a shelf life guaranteed for one year. These standards are available from [GFS Chemicals](#) under part numbers 8506 (10 NTU), 8507 (100 NTU), and 8620 (1000 NTU). Follow instructions below to establish a correlation between the standard's concentration and the sensor's voltage response. Use the equation in step 6 to calculate NTU concentrations.

- 1) Connect Turbidity Plus to a power source and multimeter; see figure 1 for details.
- 2) Fill a darkened beaker with blank sample and use Turbidity Plus to measure the voltage of the blank.

**Note: A good blank to use for this application is ultra-pure or deionized water.**

- 3) Remove Turbidity Plus from the blank, pour out the blank sample, and fill the same darkened beaker with a standard solution of known concentration.
- 4) Measure the voltage response of the standard solution.
- 5) Use the following equation to create a correlation factor:

$$[(C_{Std}) / (Volts_{Std} - Volts_{Blank})] = \text{Correlation Factor}$$

$C_{Std}$  = Concentration value of standard used for calibration

$Volts_{Std}$  = Voltage reading from standard concentration

$Volts_{Blank}$  = Voltage reading from blank

- 6) Use the following equation to calculate concentration from measured voltage response:

$$C_{Sample} = (\text{Correlation Factor}) * (Volts_{Sample} - Volts_{Blank})$$

$C_{sample}$  = Concentration of sample

$Volts_{Std}$  = Voltage reading from standard concentration



## Turbidity Plus Sensor

***Note: Calibration of Turbidity Plus is not required, but recommended.***

***Note: There is no Temperature Compensation built into Turbidity Plus. The average percentage change of blank adjusted voltage is -0.45% mv/degree °C of signal.***

# Turbidity Plus Sensor

## 4. Integration

Once Turbidity Plus has been tested and/or calibrated you can proceed with integration into your platform. Refer to the power requirements in Attachment A to make sure that your system is set up correctly. Refer below for typical use with a data acquisition system wiring configuration.

**Note: The wire colors are different for no housing or no connector versions, refer to Appendix D for the colors.**

### 4.1 Taking measurements:

1. Supply power to the sensor.
2. The digital output to the wiper trigger should normally be a “1” or high and the digital input from the Home Signal should read “0” or low.
3. Take readings if desired, readings are valid 3 seconds after full power is applied.

### 4.2 To wipe:

1. Take the digital output to the wiper trigger momentarily low or “0”. The wiper will start rotating on the transition from high to low. Multiple rotations of the wiper can be achieved by sending multiple pulses on the trigger wire while the wiper is rotating, but after each triggered rotation there must be a 50 millisecond delay before the next triggered rotation. The wiper will rotate the number of pulses it receives.
2. The home signal can be monitored on the digital input. It is normally a “0” or low. When the wiper is rotating this signal will go to a “1” or high.
3. While the wiper is rotating (when the home signal is “1”) readings are not valid.
4. When the digital input monitoring the home signal returns to “0” that means the wiper is in the home position and readings are now valid.

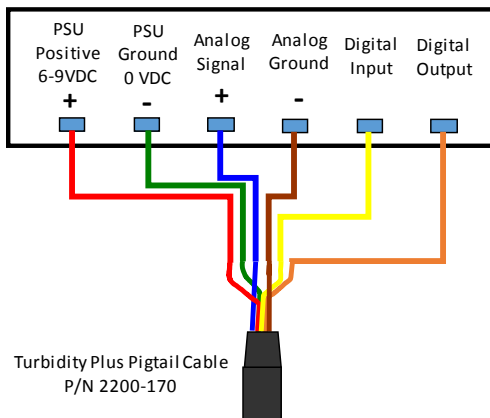

P/N 2200-170*	Turbidity Plus	Acquisition System
Red	Supply Voltage	Power Positive
Green	Supply Ground	Power Ground
Brown	Signal Ground	Analog Input Ground
Blue	Signal Out	Analog Input Signal
Orange	Wiper Trigger	Digital Output
Yellow	Home Signal	Digital Input

\* Black and White wires from the cable are not connected.

**Note: In instances where Turbidity Plus is attached with a clamp, care must be taken to not over tighten and cause damage to the outer housing as this can result in water intrusion.**

## Turbidity Plus Sensor

### 5. Maintenance and Warranty

---

#### 5.1 Maintenance

##### 5.1.1 Rinsing

Turbidity Plus should be rinsed or soaked in fresh water following each deployment, ideally, until it is completely clean again.

##### 5.1.2 Care for the bulkhead connector

A light coat of Silicone spray should be used on the rubber of the male pins of the bulkhead to aid in sealing. The manufacturer recommends 3M™ Silicone Lubricant Spray or Loctite 8021 spray.

**Note: You should avoid using silicone grease. Do NOT use WD-40, it will destroy the connectors.**



**Note: Turbidity Plus should NOT come in contact with any organic solvents (i.e. acetone, methanol) or strong acids and bases.**

#### 5.2 Warranty Terms

Turner Designs warrants Turbidity Plus and accessories to be free from defects in materials and workmanship under normal use and service for a period of 12 months from the date of shipment from Turner Designs with the following restrictions:

- Turner Designs is not responsible for replacing parts damaged by accident or neglect. Your instrument must be installed according to instructions in the User's Manual. Damage from corrosion is not covered. Damage caused by customer modification of the instrument is not covered.
- This warranty covers only Turner Designs products and is not extended to equipment used with our products. We are not responsible for incidental or consequential damages, except in those states where this limitation is not allowed. This warranty gives you specific legal rights and you may have other rights which vary from state to state.
- Damage incurred in shipping is not covered.

#### 5.3 Warranty Service

To obtain service during the warranty period, the owner shall take the following steps:

1. Write, email or call Turner Designs Technical Support and describe as precisely as possible the nature of the problem.

## Turbidity Plus Sensor

**Phone:** 1 (877) 316-8049

**Email:** [support@turnerdesigns.com](mailto:support@turnerdesigns.com)

2. Carry out any adjustments or tests as suggested by Technical Support.
3. If proper performance is not obtained you will be issued a Return Materials Authorization number (RMA) to reference. Package the unit, write the RMA number on the outside of the shipping carton, and ship the instrument, prepaid, to Turner Designs. If the failure is covered under the warranty terms the instrument will be repaired and returned free of charge, for all customers in the contiguous continental United States.

For customers outside of the contiguous continental United States who purchased equipment from one of our authorized distributors, contact the distributor. If you purchased directly, contact us. We will repair the instrument at no charge. Customer pays for shipping, duties, and documentation to Turner Designs. Turner Designs pays for return shipment (custom duties, taxes and fees are the responsibility of the customer).

### 5.4 Out-of-Warranty Service

Follow steps for Warranty Service as listed above. If Technical Support can assist you by phone or correspondence, we will be glad to, at no charge. Repair service will be billed on a fixed price basis, plus any applicable duties and/or taxes. Shipment to Turner Designs should be prepaid. Your bill will include return shipment freight charges.

**Address for Shipment:**

Turner Designs, Inc.  
1995 N. 1<sup>st</sup> Street  
San Jose, CA 95112

## Turbidity Plus Sensor



## Turbidity Plus Sensor

### Appendix A: Specifications

---

Parameter	Specification
Power Draw	@ 6V: Max 120mW signal only @ 6V: Typical 160mW while wiper rotates (power draw increases if there is resistance to the wiper)
Input Voltage	6 - 9 VDC
Signal Output	Single gain, 0 – 5 VDC Analog
MDL	0.5 NTU
Range	0-3000 NTU*
Linearity (full range)	0.99 R <sup>2</sup>
Precision	0 – 10 (± 0.1 NTU) 10 – 1000 (± 0.4 NTU) > 1000 (± 0.04% of NTU Concentration)
Wiper Trigger	Pulse to zero (ground) for wiper rotation
Minimum Pulse Width for Wiper Trigger	50 milliseconds
Temperature Range	Ambient: 0 to 50 °C Water Temp: -2 to +50 °C
Light Source	Light Emitting Diode
Excitation Wavelength	IR
Detector	Photodiode
Settling time from power on	T <sub>99</sub> = < 3 seconds
Housing Material -	Delrin
Dimensions -	L – Housing only: 4.35 in., 11.05 cm L - Housing with connector and wiper: 6.10 in., 15.49 cm; D: 1.185 in., 3.01 cm
Depth Rating	200 meters
Weight with Connector and Wiper	4.88 oz; 138 gm
Sampling focal point is in front of the sensor face	
No data averaging - analog signal output	

\*Accuracy is determined by the user's correlation between the 0-5 V output and the 0-3000 NTU range. Resolution is determined by the datalogger. Turbidity Plus are not factory calibrated.

## Turbidity Plus Sensor

### Appendix B: Recommended Measurement Practices

---

#### *Recommended Lab Practices for Measurements*

The following steps will improve the accuracy and repeatability of your measurements, especially at low concentration levels:

1. Use a non-fluorescent container for your water samples. **Note: Plastic may fluoresce and interfere with the sample's fluorescence.**
2. If using a glass container, place the container on a non-reflective black surface.
3. Ensure that the sensor is more than 3 inches above the bottom of the container.
4. Ensure that the sensor is in the center of the container and has more than 2 inches clearance between the circumference of the sensor and the inside surface of the beaker.

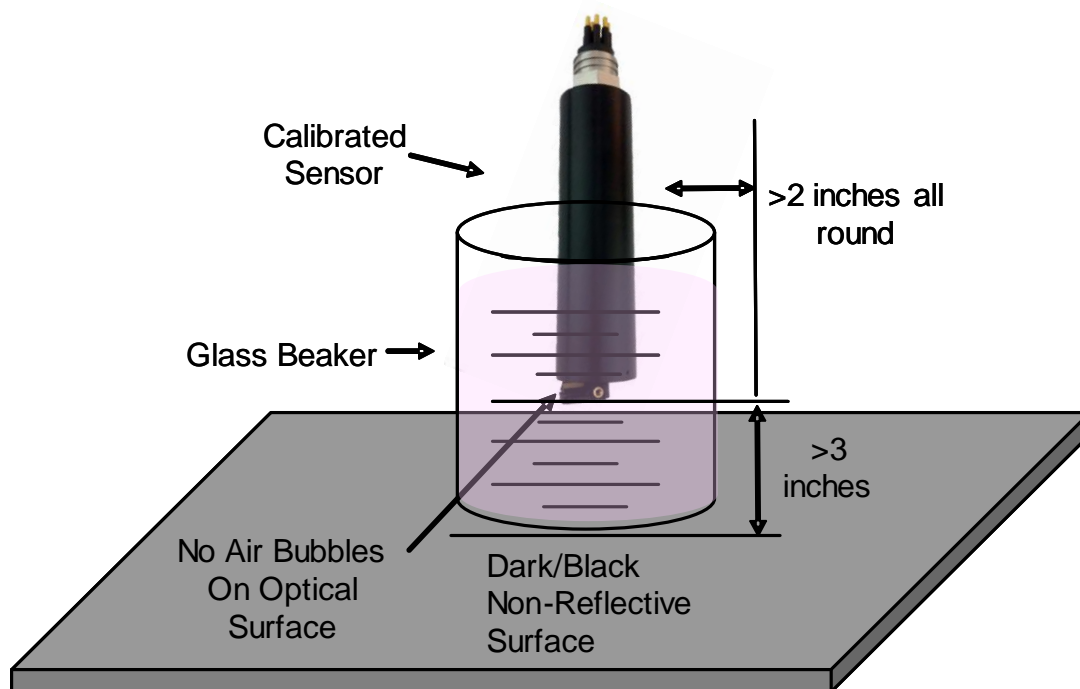

# Turbidity Plus Sensor

## Appendix C: Pigtail Cable and Connector Information

Dimension details of 24" length cable with 20 gauge colored lead wire, connects 8-pin male connector. Cable manufacturer/Part No: IMPULSE/MCIL-8-FS

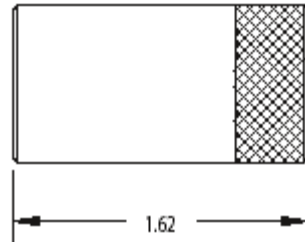
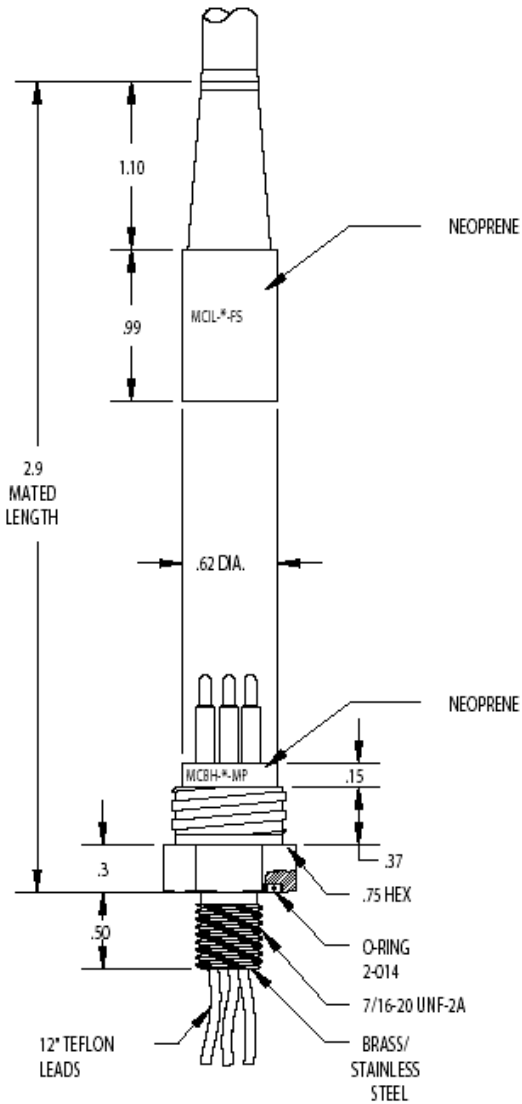

*Female locking sleeve,  
(Impulse P/No. MCDLS-F)*

Turbidity Plus pins

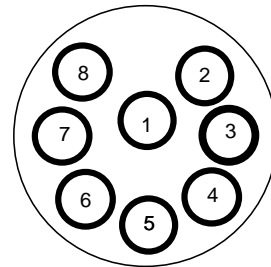

Turbidity Plus cable holes

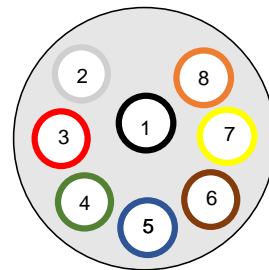

A maximum cable length up to 20 meters can be connected to Turbidity Plus if the following conditions are met:

- 1) The cable is shielded and contains 20 gauge conductor size or greater, i.e. Beldon No. 8426 cable.
- 2) The 0-5 volt Analog output is connected to a device, i.e. Data Logger with an input impedance of 1 MegOhm or greater.
- 3) The supply voltage to Turbidity Plus is between 6 and 9 volts.



## Turbidity Plus Sensor

### Appendix D: Functional Test for Turbidity Plus with no Connector

To perform a functional check on Turbidity Plus, connect Turbidity Plus colored wires to the power supply and multi-meter as shown in Figure 3 below.



No Connector Turbidity Plus P/N 2180-000-NC or NCW and No Housing Turbidity Plus 2180-000-NH or NHW.

Additional Equipment required for functional tests:  
 DC Power Supply: 6 - 9 VDC, >100 mA  
 Multi-meter to read: 0 – 5 VDC

Color	Function
Red	Supply Voltage 6-9 VDC
Black	Supply Ground 0 VDC
Orange	Signal Out "+", 0-5 VDC
Green	Signal Ground "-", 0 VDC
Blue	Home Signal
Yellow	Wiper Trigger, 3.2 VDC



**Note: Supply voltages greater than 9 VDC will result in damage to the sensor.**

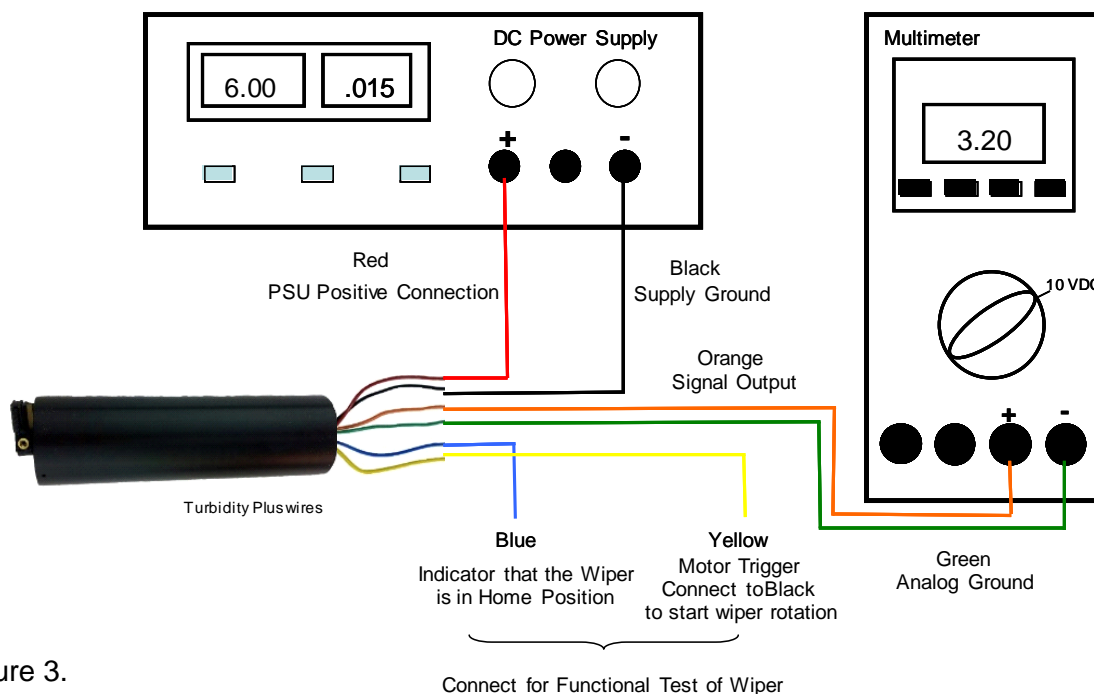

With Turbidity Plus connected as shown in Figure 3 answer questions 1-2 by making the following functional tests:

1. Is there voltage output?  
The multi-meter should be reading some voltage >0 VDC
2. Does the voltage output change?  
Move the palm of your hand towards the optical head and check if the voltage output increases.

## Turbidity Plus Sensor

**Note: A visual test of the LED functionality for Turbidity Plus is not possible because it is IR which is not visible.**

To perform a functional check on wiper, connect the colored wires to the power supply and multi-meter following the steps below, shown in Figure 4.

1. Disconnect the orange wire from the meter and connect the blue wire in its place. It should read about 0 volts when the wiper is home and 3.2 volts while the wiper is rotating and not in the home position.
2. The yellow wire is the wiper motor trigger. Briefly touch the yellow wire to the power supply ground to start the wiper rotating. The meter should read about 3.2 volts until the wiper returns to its home position.

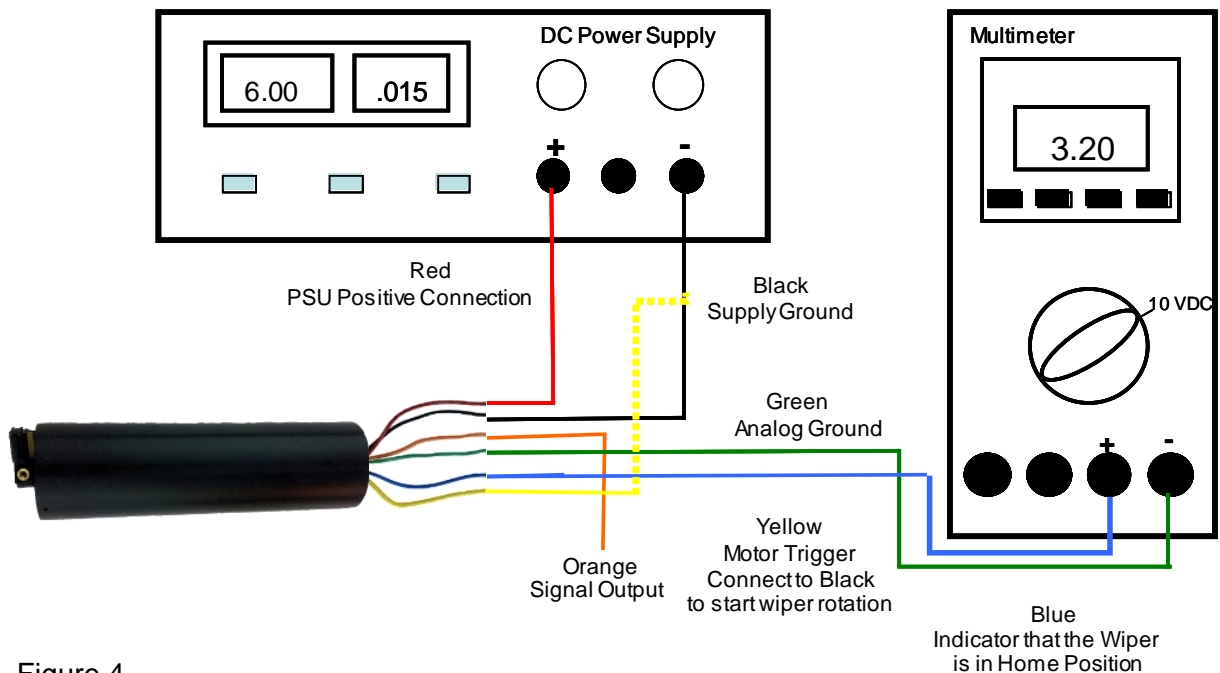

Figure 4.