

## Manganese III Reactor Digestion Method (with chloride removal)

Method 10067

30 to 1000 mg/L COD Mn

Test 'N Tube™ Vials

Scope and application: For water and wastewater



### Test preparation

### Instrument-specific information

Table 1 shows all of the instruments that have the program for this test. The table also shows adapter and light shield requirements for the instruments that use them.

To use the table, select an instrument, then read across to find the applicable information for this test.

**Table 1 Instrument-specific information for test tubes**

Instrument	Adapters	Light shield
DR 6000, DR 5000	—	—
DR 3900	—	LZV849
DR 3800, DR 2800, DR 2700	—	LZV646
DR 1900	9609900 (D <sup>1</sup> )	—
DR 900	4846400	Cover supplied with the instrument

### Before starting

Install the instrument cap on the DR 900 cell holder before ZERO or READ is pushed.

DR 3900, DR 3800, DR 2800 and DR 2700: Install the light shield in Cell Compartment #2 before this test is started.

To find if the sample contains chloride, use Quantab® Titrator Strips for low range chloride.

If the sample COD is expected to exceed 1000 mg/L, dilute the sample. Refer to [Multiplication factors for sample dilutions](#) on page 6.

Run one blank with each set of samples. Run all tests (the samples and the blank) with the same lot of vials. The lot number is on the container label.

The reagent blank vial can be used for multiple tests. Fill a clean COD vial with deionized water and use this vial to zero the instrument, then measure the absorbance of the reagent blank vial. The absorbance value should be approximately 1.41–1.47. Prepare a new reagent blank vial when the absorbance is outside of this range.

To oxidize resistant organics, samples can be digested for up to four hours. Digest the blank for the same time period as the samples.

Make sure that the filter disc is not in the center of the vial during the Zero and Read steps. Make sure that the filter disc is more than 20 mm (0.8 in.) or less than 10 mm (0.4 in.) from the bottom of the vial. If necessary, move the filter disk by gently swirling or by lightly tapping the vial on a table top.

The Chloride Removal Cartridge can be used only once.

If the sample boils during the digestion, the vial is not properly sealed. Test results will be invalid.

Spilled reagent will affect test accuracy and is hazardous. Do not run tests with spilled vials.

The maximum range of the VPD gauge is 40 inches of water; it will not indicate the full vacuum level obtained. Full vacuum is 20–25 inches of mercury; this can be measured at the vacuum pump with a gauge calibrated for inches of mercury.

<sup>1</sup> The D adapter is not available with all instrument versions.

Review the Safety Data Sheets (MSDS/SDS) for the chemicals that are used. Use the recommended personal protective equipment.

Dispose of reacted solutions according to local, state and federal regulations. Refer to the Safety Data Sheets for disposal information for unused reagents. Refer to the environmental, health and safety staff for your facility and/or local regulatory agencies for further disposal information.

## Items to collect

Description	Quantity
Blender	1
DRB200 Reactor	1
Forceps, extra fine	1
Light shield and adapter (For information about sample cells, adapters or light shields, refer to <a href="#">Instrument-specific information</a> on page 1.)	1
Manganese III COD Reagent Vials, 20 to 1000 mg/L COD	1
Pipet, TenSette, 0.1- to 1.0-mL, with pipet tips	1
Pipet, TenSette, 10.0 to 10.0-mL, with pipet tips	1
Sulfuric Acid, concentrated ACS	1 mL
Test tube rack	1
Vacuum pretreatment device	1
Vacuum pump	1
Vial, glass, for sample and acid	2
Water, deionized	varies

Refer to [Consumables and replacement items](#) on page 7 for order information.

## Sample collection and storage

- Collect samples in clean glass bottles. Use plastic bottles only if they are known to be free of organic contamination.
- Test biologically active samples as soon as possible.
- Homogenize samples that contain solids to get a representative sample.
- To preserve samples for later analysis, adjust the sample pH to less than 2 with concentrated sulfuric acid (approximately 2 mL per liter). No acid addition is necessary if the sample is tested immediately.
- Keep the preserved samples at 2–6 °C (36–43 °F) for a maximum of 28 days.
- Correct the test result for the dilution caused by the volume additions.

## Acidified sample preparation

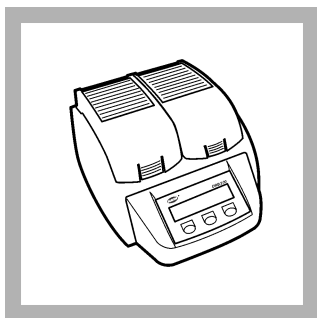

**1.** Set the DRB200 Reactor power to on. Preheat to 150 °C or set to the COD program.

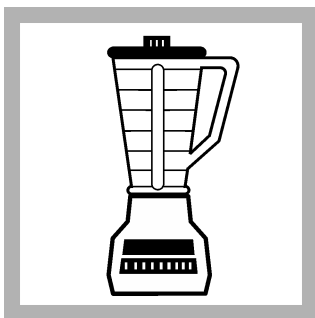

**2.** Put 100 mL of sample in a blender. Blend for 30 seconds or until homogenized.

If suspended solids are present, continue to mix the sample while the sample is moved to the mixing cell for the prepared sample.

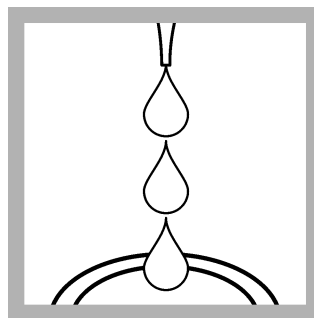

**3. Prepare the blank:** Use a pipet to add 9.0 mL of deionized water to a glass mixing cell.

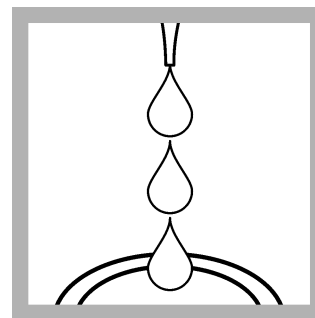

**4. Prepare the sample:** Use a pipet to add 9.0 mL of homogenized sample to a second glass mixing cell.

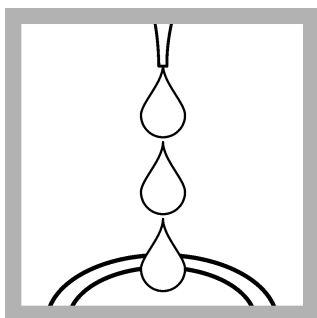

**5.** Use a pipet or dispenser to add 1.0 mL of concentrated Sulfuric Acid to both mixing cells.

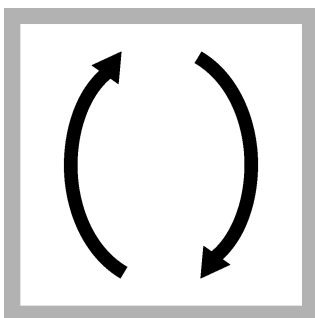

**6.** Close the mixing cells tightly. Invert several times. The cells get hot during mixing. Let the mixing cells cool to room temperature. Go to the [Vacuum pretreatment procedure](#) on page 4.

## Vacuum pretreatment procedure

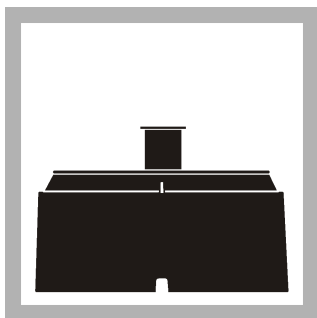

1. Attach the vacuum pretreatment device (VPD) to a vacuum pump that can create a vacuum of 20–25 inches of mercury. Do not use an aspirator type vacuum.

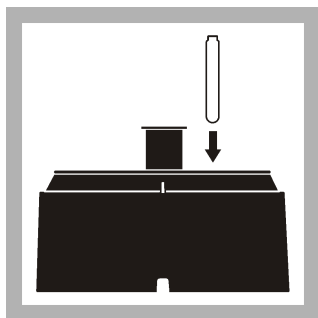

2. Write a sample identifier on each vial. Insert the Mn III COD vials in the numbered holes in the VPD base. Remove the caps from the vials.

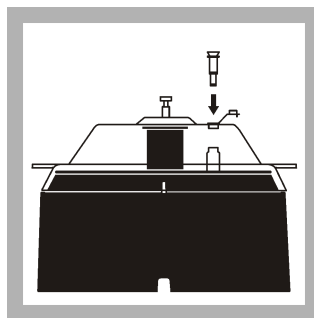

3. Put the VPD top on the base. Insert a fresh Chloride Removal Cartridge (CRC) directly above each Mn III COD Reagent Vial. Close any open holes in the VPD with the supplied stoppers.

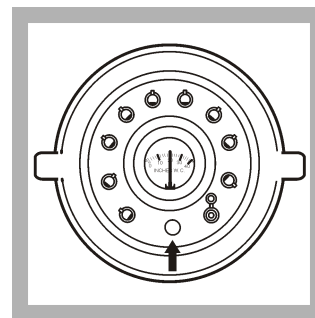

4. Start the vacuum pump. Adjust the vacuum regulator valve on top of the VPD until the internal gauge reads 20 inches of water.

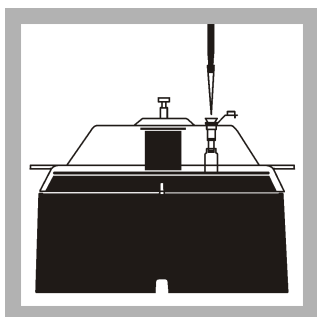

5. **Prepare the blank:** Use a pipet to add 0.60 mL of acidified blank into the CRC. It should take 30–45 seconds to pull the liquid through the CRC into the vial.

**Note:** If the liquid does not flow through the CRC, increase the vacuum until the flow starts, then reduce the vacuum back to 20 inches of water.

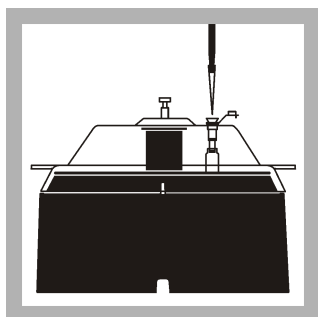

6. **Prepare the sample:** Use a pipet to add 0.60 mL of each acidified sample into the CRC.

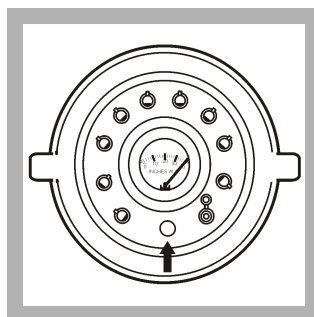

7. Close the vacuum regulator valve completely to achieve full vacuum. After one minute of full vacuum, move the VPD back and forth several times to remove drops that cling to the CRC.

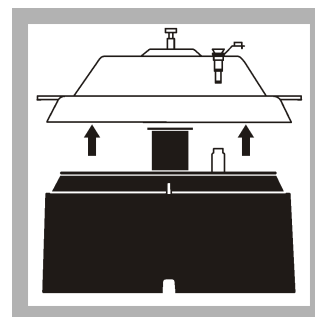

8. Open the VPD regulator to release the vacuum. Turn the pump off. Remove the VPD top and set it aside. Dispose of the used Chloride Removal Cartridges. Go to [Sample preparation and measurement](#) on page 5.

## Sample preparation and measurement

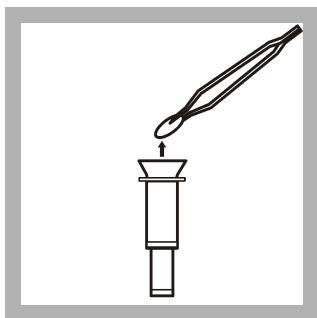

1. Use forceps to remove the filter from the top of the CRC. If the sample does not contain suspended solids, it is not necessary to transfer the filter to the digestion vial.

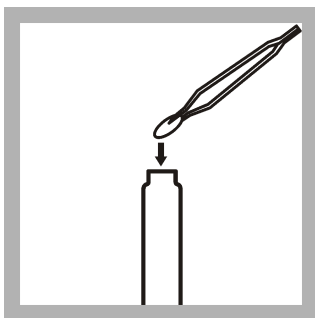

2. Insert each filter into the corresponding Mn III COD vial. Use the numbers on the VPD as a guide. Use a clean towel or deionized water to clean the forceps between samples.

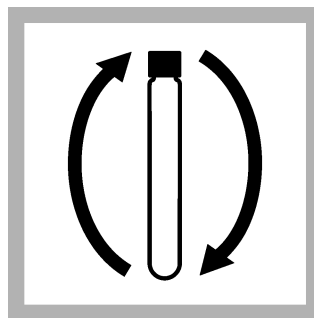

3. Remove the Mn III COD vial from the vacuum chamber. Put the original caps on and close tightly. Invert the vials several times to mix.

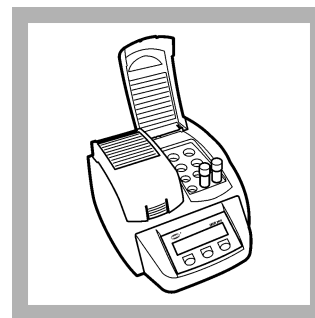

4. Insert the vials in the DRB200 Reactor at 150 °C. Close the cover. Digest the samples for one hour.

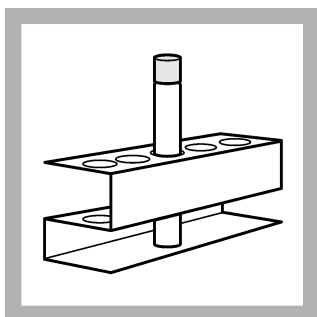

5. After an hour, remove the vials from the DRB200. Let the vials cool in a rack for two minutes. If the solution develops a colorless upper layer and a purple lower layer, invert the vials several times to mix.

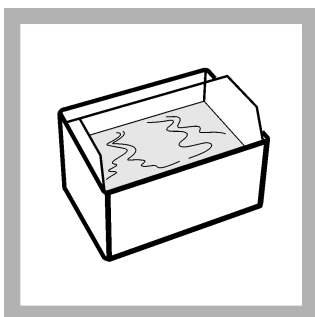

6. Let the vials cool to room temperature in a cool water bath, or hold under running tap water for several minutes.

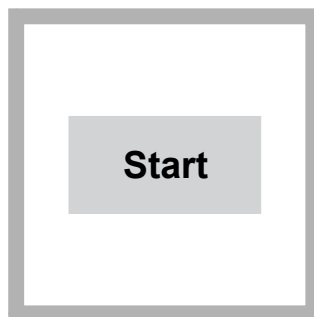

7. Start program **432 COD Mn III**. For information about sample cells, adapters or light shields, refer to [Instrument-specific information](#) on page 1.

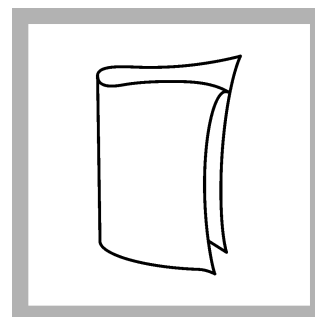

8. Clean the blank vial.

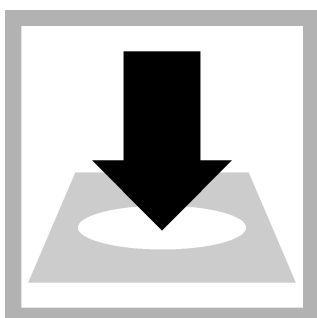

9. Insert the blank vial into the 16-mm cell holder. Make sure that the filter disc does not block the instrument light beam. Refer to [Before starting](#) on page 1.

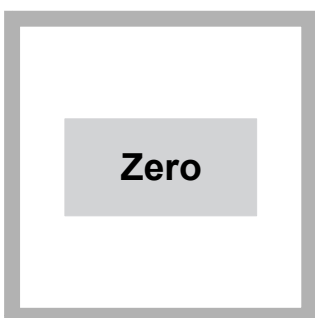

10. Push **ZERO**. The display shows 0 mg/L COD Mn.

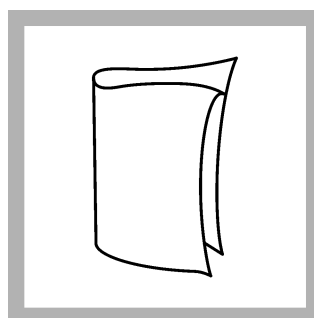

11. Clean the sample vial.

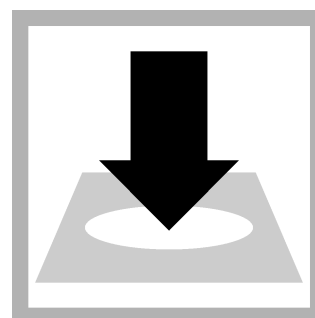

12. Insert the sample vial into the 16-mm cell holder. Make sure that the filter disc does not block the instrument light beam. Refer to [Before starting](#) on page 1.



**Read**

13. Push **READ**. Results show in mg/L COD Mn.

## Multiplication factors for sample dilutions

If the sample COD is expected to exceed 1000 mg/L, dilute the sample as shown in [Table 2](#). For other dilutions not shown, add the sample volume and the deionized water and divide by the sample volume to obtain the multiplication factor. All dilutions require that the ratio of sample to sulfuric acid remain at 9:1.

**Note:** *Mixing concentrated sulfuric acid and water is not additive. Adding 1.0 mL of concentrated sulfuric acid to 9.0 mL of sample does not result in a final volume of 10.0 mL. This factor is built into the calibration curve.*

**Table 2 Multiplication factors**

Sample (mL)	Deionized water (mL)	Range (mg/L COD)	Multiplication factor
6.0	3.0	30–1500	1.5
3.0	6.0	60–3000	3
1.0	8.0	180–9000	9
0.5	8.5	360–18,000	18

For best results, use a minimum of 0.5 mL sample for the dilution. If the sample values exceed 18,000 mg/L COD, use a separate sample dilution, then start the sample chloride removal procedure.

**Example:** Dilute the sample to a range of 90–4500 mg/L COD.

Sample Volume (2.0 mL) + Deionized water (7.0 mL) = Total Volume (9.0 mL)

Multiplication factor = (total volume)/(sample volume) = 9.0 mL/2.0 mL = 4.5

Standard test range is 50 to 1000 mg/L COD.

Example test range = 4.5(50) to 4.5(1000) = 225 to 4500 mg/L COD

## Interferences

Inorganic materials can also be oxidized by trivalent manganese and cause a positive interference when present in significant concentrations. Chloride is the most common interference and is removed by sample pretreatment with the Chloride Removal Cartridge. Refer to the Oxygen Demand, Chemical procedure that uses the Manganese III Reactor Digestion Method (with chloride removal). If chloride is known to be absent or present in insignificant concentrations, the pretreatment is not necessary. A simple way to determine if chloride has an effect on the test results is to run routine samples with and without the chloride removal, then compare results.

Other inorganic interferences (e.g., nitrite, ferrous iron, sulfide) are not usually present in significant amounts. If necessary, determine the concentration of these interferences with separate methods, then adjust the final COD test results accordingly.

Ammonia nitrogen is known to interfere in the presence of chloride. Ammonia nitrogen does not interfere if chloride is absent.

## Accuracy check

### Standard solution method

Use the standard solution method to validate the test procedure, the reagents and the instrument.

Items to collect:

- COD standard solution, 800 mg/L (use 0.60 mL in place of the sample)
1. Use the test procedure to measure the concentration of the standard solution.
  2. Compare the expected result to the actual result.

**Note:** The factory calibration can be adjusted slightly with the standard adjust option so that the instrument shows the expected value of the standard solution. The adjusted calibration is then used for all test results. This adjustment can increase the test accuracy when there are small variations in the reagents or instruments.

### Method performance

The method performance data that follows was derived from laboratory tests that were measured on a spectrophotometer during ideal test conditions. Users can get different results under different test conditions.

Program	Standard	Precision (95% confidence interval)	Sensitivity Concentration change per 0.010 Abs change
432	600 mg/L COD	576–624 mg/L COD	8 mg/L COD

### Estimated detection limit

The EDL for program 432 is 4 mg/L COD. The EDL is the calculated lowest average concentration in a deionized water matrix that is different from zero with a 99% level of confidence.

### Summary of method

Chemical Oxygen Demand (COD) is defined as a measure of the oxygen equivalent of the organic matter content of a sample that is susceptible to oxidation by a strong chemical oxidant (APHA Standard Methods, 19th ed., 1995). Trivalent manganese is a strong, non-carcinogenic chemical oxidant that changes quantitatively from purple to colorless when it reacts with organic matter. It typically oxidizes about 80% of the organic compounds. Studies have shown that the reactions are highly reproducible and test results correlate closely to Biochemical Oxygen Demand (BOD) values and hexavalent chromium COD tests. None of the oxygen demand tests provide 100% oxidation of all organic compounds.

A calibration is provided which is based on the oxidation of Potassium Acid Phthalate (KHP). A different response may be seen in analyzing various wastewaters. The KHP calibration is adequate for most applications. The highest degree of accuracy is obtained when test results are correlated to a standard reference method such as BOD or one of the chromium COD methods. Special waste streams or classes will require a separate calibration to obtain a direct mg/L COD reading or to generate a correction factor for the precalibrated KHP response. The sample digestion time can be extended up to four hours for samples that are difficult to oxidize. Test results are measured at 510 nm in spectrophotometers and 520 nm in colorimeters.

### Consumables and replacement items

#### Required reagents

Description	Quantity/test	Unit	Item no.
Manganese III COD Reagent Vials	1	25/pkg	2623425
Chloride Removal Cartridge (CRC)	1	25/pkg	2661825

## Consumables and replacement items (continued)

Description	Quantity/test	Unit	Item no.
Sulfuric Acid, concentrated, ACS	75 mL	2.5 L	97909
Water, deionized	varies	4 L	27256

## Required apparatus

Description	Quantity/test	Unit	Item no.
Blender, 2-speed, 120 VAC option	1	each	2616100
Cap, with inert Teflon liner, for mixing bottle	varies	12/pkg	2401812
Cell, mixing	2	each	2427700
DRB 200 Reactor, 110 VAC option, 15 x 16-mm wells	1	each	LTV082.53.40001
DRB 200 Reactor, 220 VAC option, 15 x 16-mm wells	1	each	LTV082.52.40001
Forceps, extra fine point	1	each	2669600
Pipet, TenSette, 1.0–10.0 mL	1	each	1970010
Pipet tips, for TenSette Pipet, 1.0–10.0 mL	varies	50/pkg	2199796
Pipet, TenSette, 0.1–1.0 mL	1	each	1970001
Pipet tips, for TenSette Pipet, 0.1–1.0 mL	2	50/pkg	2185696
Test tube rack	1	each	1864100
Vacuum Pretreatment Device (VPD) <sup>2</sup>	1	each	—
Vacuum Pump, 1.2 CFM 115 V	1	each	2824800

## Recommended standards

Description	Unit	Item no.
COD Standard Solution, 800-mg/L	200 mL	2672629
Oxygen Demand Standard (BOD, COD, TOC), 10-mL ampules	16/pkg	2833510
Potassium Acid Phthalate (KHP), ACS	500 g	31534
Wastewater Influent Standard Solution, Mixed Parameter, for NH <sub>3</sub> -N, NO <sub>3</sub> -N, PO <sub>4</sub> , COD, SO <sub>4</sub> , TOC	500 mL	2833149

## Optional reagents and apparatus

Description	Unit	Item no.
Dispenser, automatic, 1.0–5.0 mL	each	2563137
Titration Strips, Quantab, for low range chloride	40 tests	2744940
Finger cots	2/pkg	1464702
Paper, pH, 0–14 pH range	100/pkg	2601300
COD Standard Solution, 300-mg/L	200 mL	1218629
COD Standard Solution, 300-mg/L	500mL	1218649
COD Standard Solution, 1000-mg/L	200 mL	2253929
<i>Standard Methods for the Examination of Water and Wastewater</i> (current edition)	each	2270800

<sup>2</sup> The Vacuum Pretreatment Device is obsolete. There is no replacement.



---

**Optional reagents and apparatus (continued)**

Description	Unit	Item no.
Pipet tips for TenSette Pipet, 1.0–10.0 mL	250/pkg	2199725
Pipet tips for TenSette Pipet, 0.1–1.0 mL	1000/pkg	2185628



**FOR TECHNICAL ASSISTANCE, PRICE INFORMATION AND ORDERING:**  
In the U.S.A. – Call toll-free **800-227-4224**  
Outside the U.S.A. – Contact the **HACH office or distributor serving you.**  
On the Worldwide Web – **[www.hach.com](http://www.hach.com)**; E-mail – **[techhelp@hach.com](mailto:techhelp@hach.com)**

**HACH COMPANY**  
WORLD HEADQUARTERS  
Telephone: (970) 669-3050  
FAX: (970) 669-2932